

DIGITAL SOUND FIELD PROCESSING AMPLIFIER

DSP-A590

SERVICE MANUAL

DSP-A590

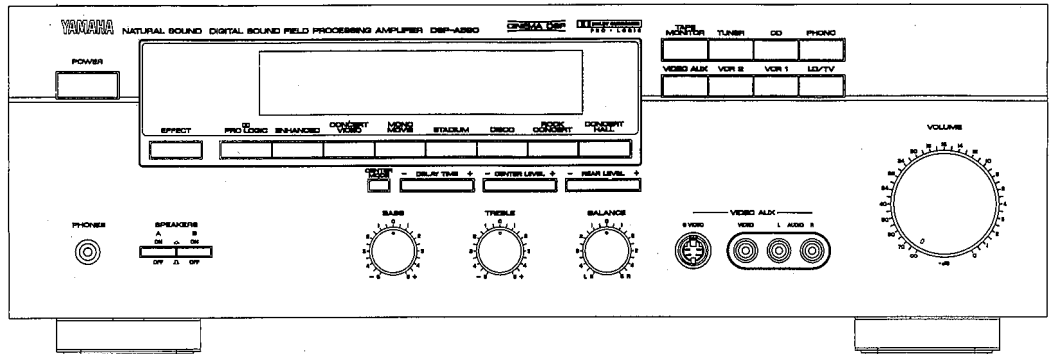
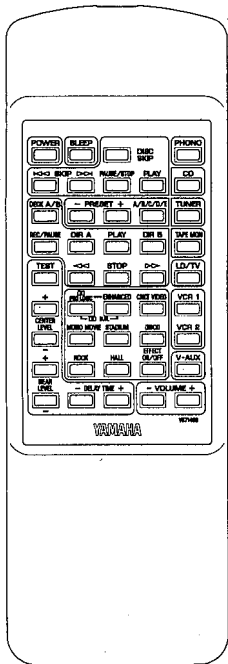

IMPORTANT NOTICE

This manual has been provided for the use of authorized YAMAHA Retailers and their service personnel. It has been assumed that basic service procedures inherent to the industry, and more specifically YAMAHA Products, are already known and understood by the users, and have therefore not been restated.

WARNING: Failure to follow appropriate service and safety procedures when servicing this product may result in personal injury, destruction of expensive components and failure of the product to perform as specified. For these reasons, we advise all YAMAHA product owners that all service required should be performed by an authorized YAMAHA Retailer or the appointed service representative.

IMPORTANT: The presentation or sale of this manual to any individual or firm does not constitute authorization, certification or recognition of any applicable technical capabilities, or establish a principle-agent relationship of any form.

The data provided is believed to be accurate and applicable to the unit(s) indicated on the cover. The research, engineering, and service departments of YAMAHA are continually striving to improve YAMAHA products. Modifications are, therefore, inevitable and specifications are subject to change without notice or obligation to retrofit. Should any discrepancy appear to exist, please contact the distributor's Service Division.

WARNING: Static discharges can destroy expensive components. Discharge any static electricity your body may have accumulated by grounding yourself to the ground buss in the unit (heavy gauge black wires connect to this buss).

IMPORTANT: Turn the unit OFF during disassembly and parts replacement. Recheck all work before you apply power to the unit.

CONTENTS

TO SERVICE PERSONNEL	1
REAR PANELS	1~2
INTERNAL VIEW	2
SPECIFICATIONS	3
DISASSEMBLY PROCEDURES	4
SELF CHECK MODE	4~6
IC DATA	7~10

DISPLAY DATA	11
PRINTED CIRCUIT BOARD	12~21
BLOCK DIAGRAM	22~23
IC BLOCKS	24~25
SCHEMATIC DIAGRAM	26~28
PARTS LIST	29~39
REMOTE CONTROL TRANSMITTER	40

100513

YAMAHA

YAMAHA CORPORATION
P.O.Box 1, Hamamatsu, Japan

2.15K-384 ☐ Printed in Japan '95.3

TO SERVICE PERSONNEL

Critical Components Information.
Components having special characteristics are marked and must be replaced with parts having specifications equal to those originally installed.

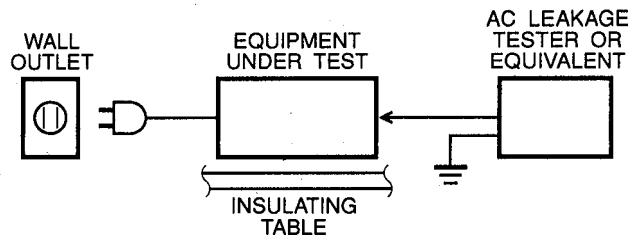

DSP-A590

REAR PANELS

▼ R model

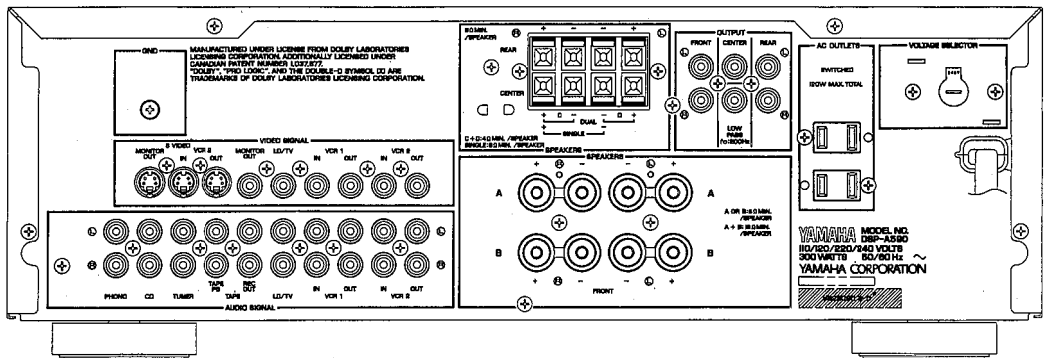

▼ A model

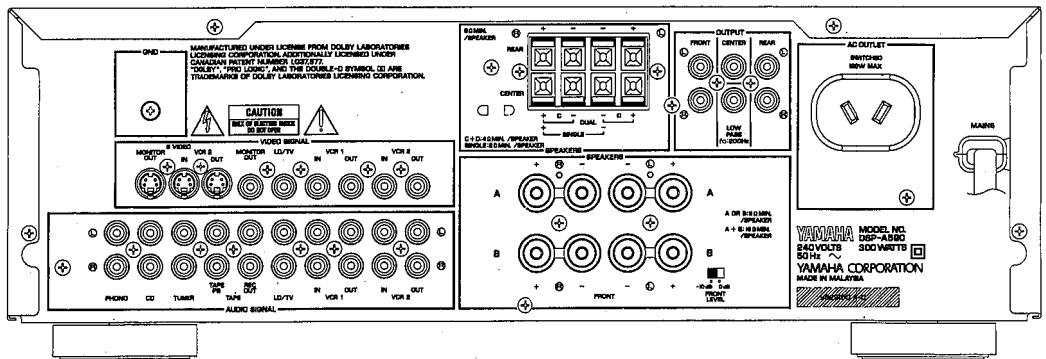

▼ B model

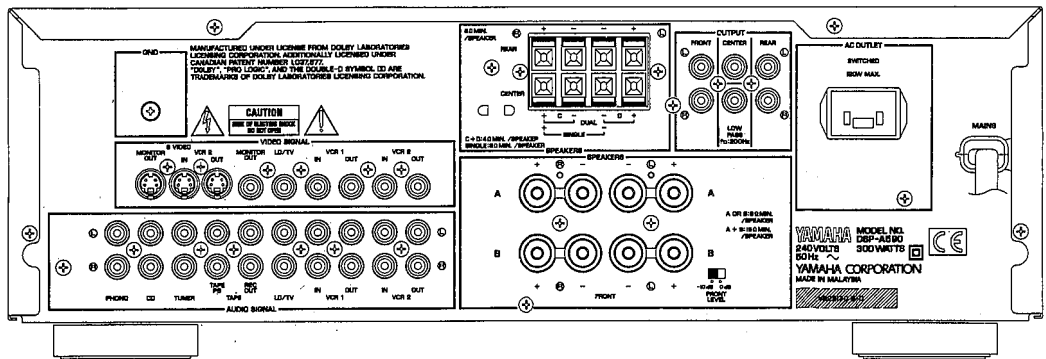

▼ G model

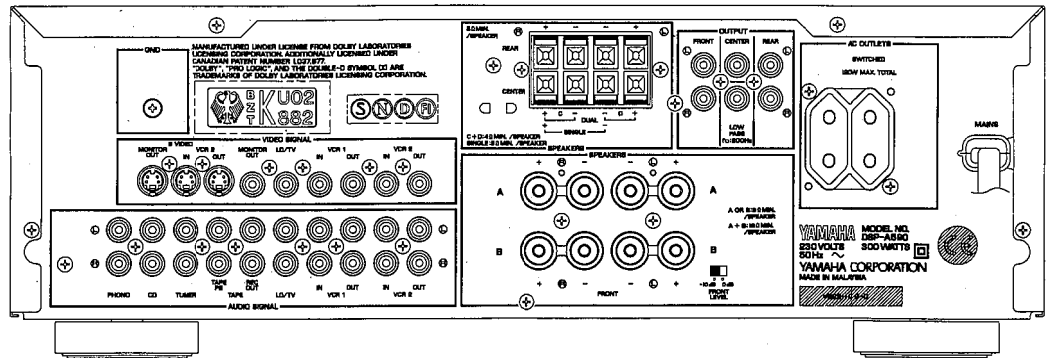

■ INTERNAL VIEW

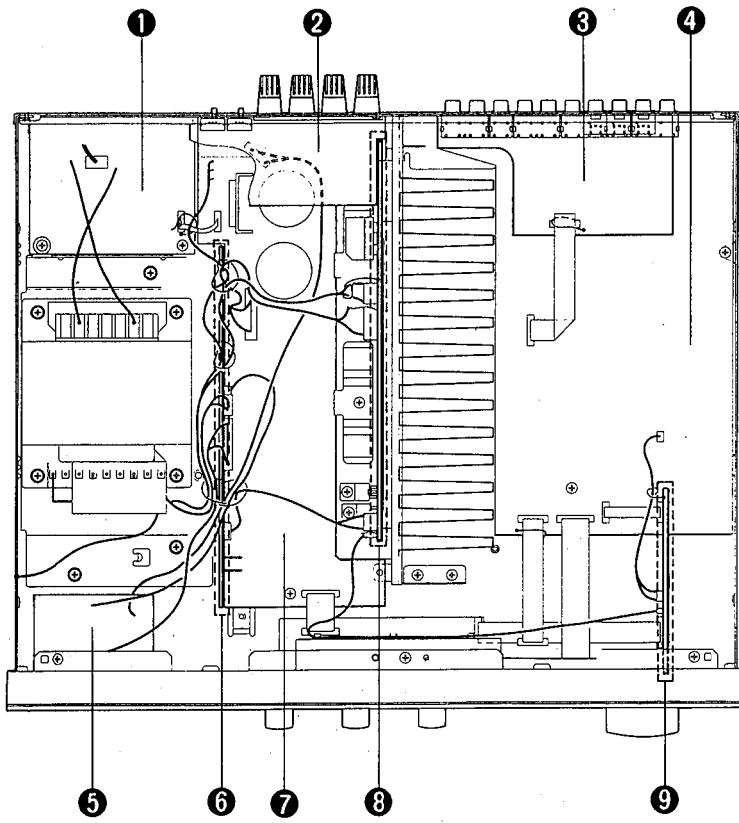

- ① P. C. B. MAIN (6)
- ② P. C. B. MAIN (5)
- ③ P. C. B. DSP (3)
- ④ P. C. B. DSP (1)
- ⑤ P. C. B. MAIN (3)
- ⑥ P. C. B. MAIN (2)
- ⑦ P. C. B. MAIN (1)
- ⑧ P. C. B. MAIN (4)
- ⑨ P. C. B. DSP (2)

■ SPECIFICATIONS

Minimum RMS Output Power Per Channel	
FRONT (20Hz—20kHz, 0.04% THD, 8Ω)	70W
CENTER (20Hz—20kHz, 0.07% THD, 8Ω)	70W
REAR (1kHz, 0.3% THD, 8Ω)	20W
Maximum Power (R model)	
FRONT (1kHz, 10% THD, 8Ω)	105W
Dynamic Power Per Channel (by IHF Dynamic Headroom Measuring Method)	
FRONT (8Ω/6Ω/4Ω/2Ω)	95W/120W/150W/170W
DIN Standard Output Power Per Channel (G model)	
FRONT (1kHz, 0.7% THD, 4Ω)	100W
IEC Power (G model)	
FRONT (1kHz, 0.1% THD, 8Ω)	78W
Power Band Width	
FRONT (0.08% THD, 30W/8Ω)	10Hz—50kHz
Damping Factor	
FRONT (20Hz—20kHz, 8Ω)	80
Input Sensitivity/Impedance	
PHONO (MM)	2.5mV/47kΩ
CD etc	150mV/47kΩ
Maximum Input Signal (1kHz, 0.5% THD)	
PHONO (MM)	115mV
CD etc	2.2V
Output Level/Impedance (EFFECT OFF)	
REC OUT	150mV/1kΩ
PRE OUT (FRONT/CENTER/REAR)	2.2V/1.2kΩ
PRE OUT (LOW PASS)	3.5V/1.5kΩ
Headphone Jack Rated Output/Impedance	
Input 1kHz, 150mV, 8Ω	0.5V/390Ω
Frequency Response (20Hz—20kHz)	
CD etc. to FRONT L, R	0±0.5dB
RIAA Equalization Deviation(20Hz—20kHz)	
PHONO (MM)	0±0.5dB
Total Harmonic Distortion	
PHONO (MM) to REC OUT (20Hz—20kHz) 1V	0.02%
CD etc. to FRONT SP out	
20Hz—20kHz, 30W/8Ω (EFFECT OFF)	0.02%
CD etc. to REAR SP out (1kHz) 10W/8Ω	0.3%
Signal-to-Noise Ratio (IHF-A-Network)	
PHONO (MM), Input Shorted, (5mV), REC OUT	
R, A models	85dB
B, G models	82dB
CD etc, Input Shorted, EFFECT OFF, SP out	99dB
Residual Noise (IHF-A-Network)	
FRONT L, R SP out	140μV
Channel Separation (Vol -30dB, EFFECT OFF)	
PHONO (MM), Input Shorted, 1kHz/10kHz	60dB/50dB
CD etc, Input 5.1kΩ Shorted, 1kHz/10kHz	60dB/44dB
Tone Control Characteristics	
Bass Boost/Cut	±10dB (50Hz)
Turnover frequency	350Hz
Treble Boost/Cut	±10dB (20kHz)
Turnover frequency	3.5kHz
Filter Characteristics	
LPF	fc=200Hz, 6dB/oct
Gain Tracking Error (0dB to -60dB)	
	3dB

Video

Video Signal Level		1Vp-p/75Ω
S-Video Signal Level	Y	1Vp-p/75Ω
	C	0.286Vp-p/75Ω
Maximum Input Level		1.5Vp-p
S/N		50dB
Monitor Out Frequency Response		5Hz—10MHz, -3dB

Power Supply

A, B models	AC240V 50Hz
G model	AC230V 50Hz
R model	AC110/120/220/240V 60/50Hz

Power Consumption

300W

AC Outlets

2 Switched Outlets (R, G models)	120W max. total
1 Switched Outlet (A, B, models)	120W max.

Dimensions (W x H x D)

435 x 146 x 386mm
(17-1/8" x 5-3/4" x 15-3/16")

Weight

10.0kg (22 lbs.)

*Specifications are subject to change without notice.

B British model

A Australian model

G European model

R General model

Manufactured under license from Dolby Laboratories Licensing Corporation. Additionally licensed under Canadian patent number 1,037,877. "Dolby", "Pro Logic", and the double-D symbol  are trademarks of Dolby Laboratories Licensing Corporation.

● DIMENSIONS

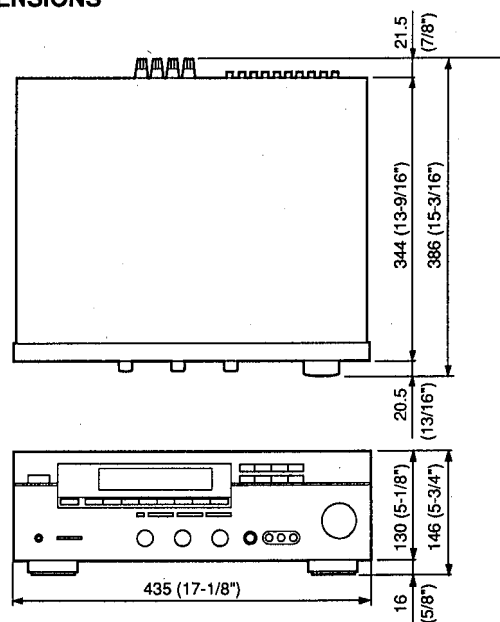

Unit : mm (inch)

DISASSEMBLY PROCEDURES (Remove parts in disassembly order as numbered.)

1. Removal of Top Cover

a. Remove 4 screws (①) and 4 screws (②) in Fig. 1.

2. Removal of Bottom Cover

a. Remove 6 screws (③) in Fig. 1.

3. Removal of Front Panel

a. Remove 4 knobs.

b. Remove 6 screws (④) in Fig. 1.

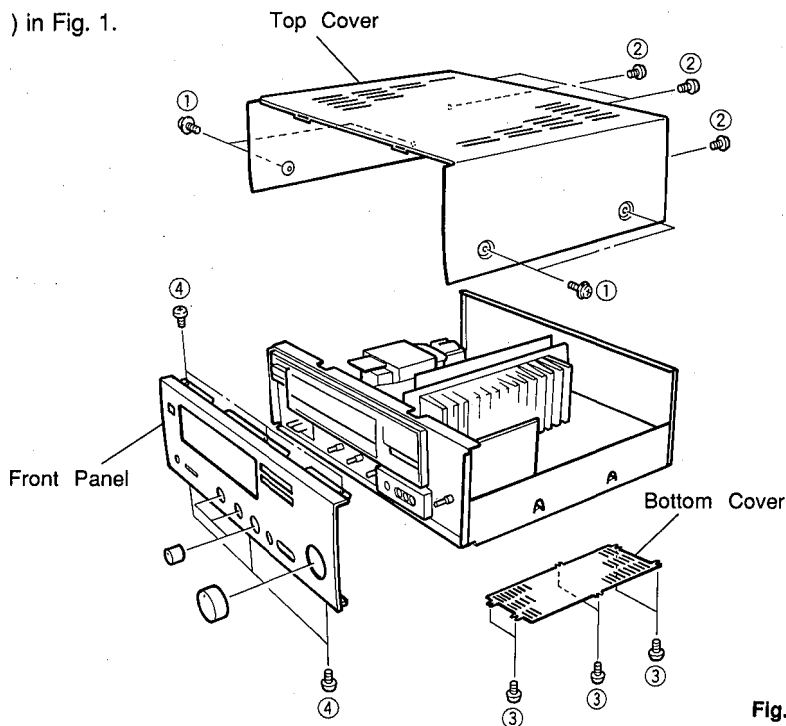

Fig. 1

SELF CHECK MODE

This model has the SELF CHECK MODE for facilitating measurement and inspection.

HOW TO START

Turn the POWER switch ON while pressing the DOLBY PRO LOGIC, ENHANCED, CONCERT VIDEO keys simultaneously, and then the unit enters the SELF CHECK MODE. (FL displays "1 SELF")

HOW TO EXIT

Turning the POWER switch OFF or pressing the CONCERT HALL key cancels the SELF CHECK MODE. (The unit enters normal mode)

CONTENTS OF SELF CHECK MODE

No.	Menu	Sub Menu	Select Key
1	MAIN BYPASS		<input type="checkbox"/> PRO LOGIC
2	FRONT EFFECT		ENHANCED
3	MAIN DSP		CONCERT VIDEO
4	DISPLAY CHECK and EFFECT OFF		MONO MOVIE
5	MANUAL TEST TONE	LEFT/CENTER/RIGHT/SURROUND	STADIUM
6	DOLBY PRO LOGIC		DISCO
7	KEEP DATA	FACTORY PRESET	ROCK CONCERT
(8)	The SELF CHECK MODE is cancelled and returns to the normal operation mode. (MODE EXIT)		CONCERT HALL

HOW TO USE SELF CHECK MODE

In order to confirm characteristics (specifications) listed in the table below, use SELF NO. 1, 3 and 4. (For specifications, refer to page 3.)

No.	Items
1	<ul style="list-style-type: none"> • Output Level/Impedance • Frequency Response • Total Harmonic Distortion (Rec Out & Front) • S/N
3	<ul style="list-style-type: none"> • Minimum RMS Output Power Per Channel (Center & Rear) • Total Harmonic Distortion (Rear)
4	<ul style="list-style-type: none"> • Minimum RMS Output Power Per Channel (Front) • Input Sensitivity/Impedance • Headphone Jack Rated Output/Impedance • Channel Separation • Tone Control Characteristics

DETAILS OF SELF CONTENT

SELF 1 MAIN BYPASS

- L/R is output through the bypass.
- CENTER is output with the steering OFF and (L+R)/2.
- RL/RR passes through the PS-RAM and is output through the DSP.
- CENTER level and REAR level are 60 (-10dB).
- FL displays "1 SELF"

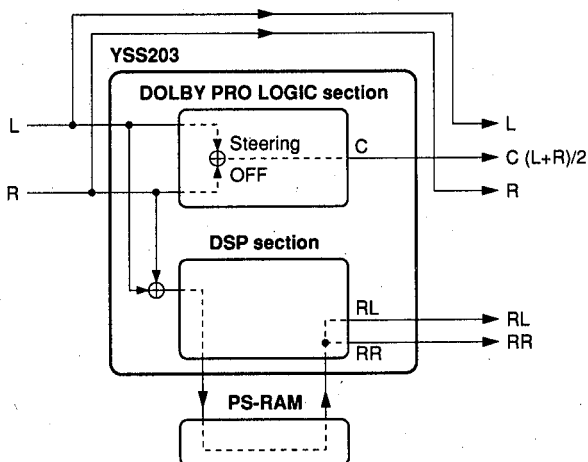

CD INPUT : 1kHz, -20dB
 VOLUME : MAX
 PRE OUT : FRONT +3.3dB±1dB
 : REAR -6.2dB±1dB
 : CENTER -6.2dB±1dB

SELF 2 FRONT EFFECT

- L/R and RL/RR pass through the PS-RAM and are output through the DSP.
- CENTER is output with the steering OFF and (L+R)/2.
- CENTER level and REAR level are 60 (-10dB).
- FL displays "2 SELF"

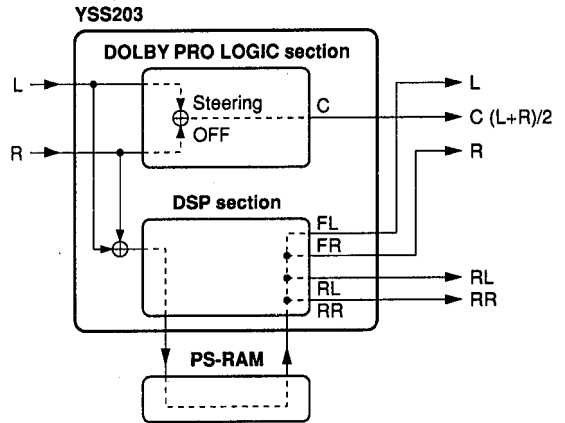

CD INPUT : 1kHz, -20dB
 VOLUME : MAX
 PRE OUT : FRONT +3.3dB±1dB
 : REAR -6.2dB±1dB
 : CENTER -6.5dB±1dB

SELF 3 MAIN DSP

- L/R is output with the steering OFF.
- CENTER is output with the steering OFF and (L+R)/2.
- RL/RR passes through the PS-RAM and is output through the DSP.
- CENTER level and REAR level are 100 (+10dB).
- FL displays "3 SELF"

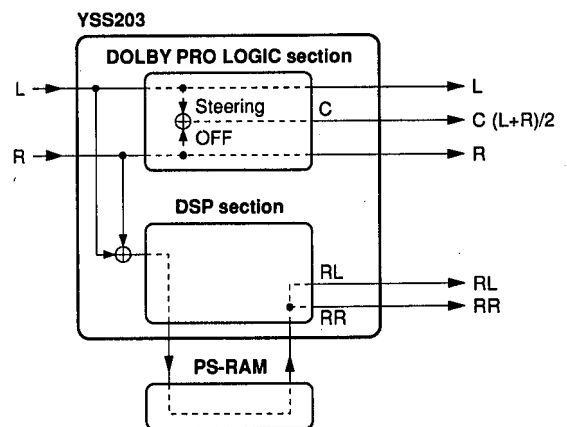

CD INPUT : 1kHz, -35dB
 VOLUME : MAX
 PRE OUT : FRONT -11.7dB±1dB
 : REAR -1.2dB±1dB
 : CENTER -1.2dB±1dB

SELF 4 DISPLAY CHECK and EFFECT OFF

- Every FL segment turns ON for 3 second.
- L/R is output through the bypass.
- FL displays "4 SELF"

CD INPUT : 1kHz, -35dB
 VOLUME : MAX
 PRE OUT : FRONT -11.6dB±1dB
 : REAR -∞dB
 : CENTER -∞dB

SELF 5 MANUAL TEST TONE

- Every time STADIUM key is pressed, the TEST TONE shifts in the order of L→C→R→S and is output.
- The FL displays "L", "C", "R", "S" respectively, the "5 SELF" and "TEST" indicators flash.

SELF 6 DOLBY PRO LOGIC

- The auto input balance which is ON in the normal mode is turned OFF.
- CENTER MODE is changed by pressing the DISCO key or the CENTER MODE key.
- The FL displays "6 SELF" and the center mode.

SELF 7 KEEP DATA and PRESET

- When the unit enters the SELF 7, "7 KEEP DATA" appears on the display. And by pressing again the ROCK CONCERT key, the unit enters the PRESET MODE. In this mode, by turning off the POWER, FACTORY PRESET will be done.

● **Factory Preset**

1) **SURROUND section**

DELAY TIME	:	<input type="checkbox"/> PRO LOGIC	20ms
		ENHANCED	20ms
		CONCERT VIDEO	28ms
		MONO MOVIE	20ms
		STADIUM	45ms
		DISCO	14ms
		ROCK CONCERT	17ms
		CONCERT HALL	30ms

CENTER MODE	:	NORMAL	
VOLUME LEVEL	:	CENTER	80
		REAR	80

2) **SELECTOR section**

INPUT	:	CD
VIDEO (BGV)	:	LD/TV

IC DATA

IC903 : M38102M4-621SP
8 bit μ -COM

DSP-A590

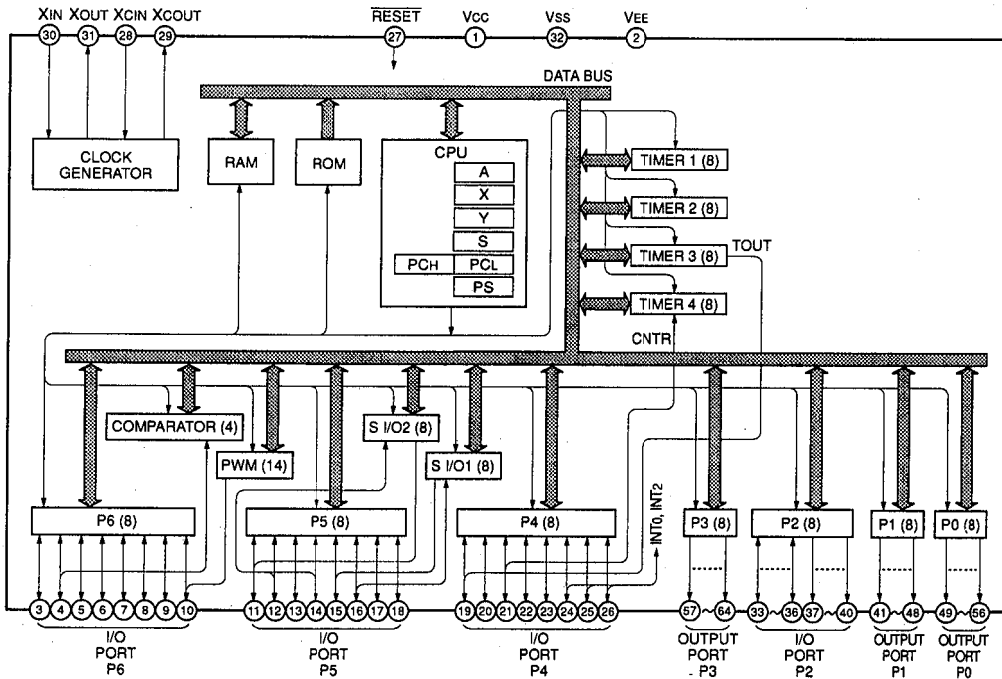
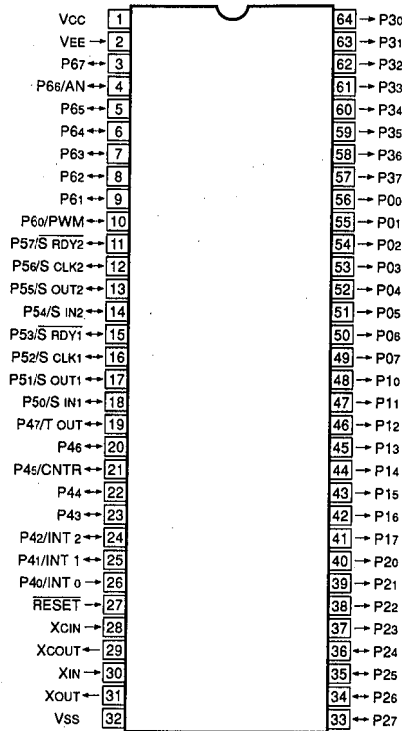

No.	Port	Name	I/O	Function	Logic
1	Vcc	VCC	—	+5V	
2	Vee	VEE	—	-V(-25V)	
3	P67	FMT	O	FULL MUTE out	L : ON
4	P66		—	N.C.	
5	P65	SPRY	O	Speaker relay out	H : ON
6	P64	PRY	O	Power relay out	H : ON
7	P63	PSW	I	Power switch in	H : ON
8	P62	PRT1	I	Protection 1 detect (The power turns OFF if "L" 2 seconds after the power is turned ON.)	L : PRT

No.	Port	Name	I/O	Function	Logic																																																												
9	P61	PRT2	I	Protection 2 detect (The power turns OFF if "H" after the power is turned ON.)	H : PRT																																																												
10	P60	PDET	I	Power down detect	L : DOWN																																																												
11	P57	STBY	I/O	Standby In : H (G model) L : LED ON																																																													
12	P56	SCK	O	SCLK 2 serial clock																																																													
13	P55	SDT	O	SOUT 2 serial data																																																													
14	P54		—	N.C.																																																													
15	P53	RDSSEL(\$16)	I/O	RDS select (H : RDS) GND																																																													
16	P52		—	N.C.																																																													
17	P51		—																																																														
18	P50		—																																																														
19	P47		—																																																														
20	P46		—																																																														
21	P45	CKB	O	BU2090 clock out																																																													
22	P44	DTB	O	BU2090 data out																																																													
23	P43	VOLU	O	VOL UP out																																																													
24	P42	VOLD	O	VOL DOWN out																																																													
25	P41	AVX/RX	I	Model select (H : AVX model) +5V																																																													
26	P40	REM	I	Remote control signal input																																																													
27	RESET	RESET	I	Reset	L : Reset																																																												
28	XCI	XCIN	I	GND																																																													
29	XCO	XCOUT	O	N.C.																																																													
30	XIN	XIN	I	Clock (4MHz)																																																													
31	XOUT	XOUT	O																																																														
32	VSS	VSS	—	GND																																																													
33	P27	K4	I	Key matrix in	<table border="1"> <thead> <tr> <th></th> <th>K1</th> <th>K2</th> <th>K3</th> <th>K4</th> </tr> </thead> <tbody> <tr> <td>D3</td> <td>—</td> <td>—</td> <td>—</td> <td>—</td> </tr> <tr> <td>D4</td> <td>PRO LOGIC</td> <td>ENHANCED</td> <td>CONCERT VIDEO</td> <td>MONO MOVIE</td> </tr> <tr> <td>D5</td> <td>STADIUM</td> <td>DISCO</td> <td>ROCK CONCERT</td> <td>CONCERT HALL</td> </tr> <tr> <td>D6</td> <td>—</td> <td>—</td> <td>—</td> <td>—</td> </tr> <tr> <td>D7</td> <td>—</td> <td>—</td> <td>—</td> <td>—</td> </tr> <tr> <td>D8</td> <td>EFFECT</td> <td>CENTER MODE</td> <td>DELAY TIME -</td> <td>DELAY TIME +</td> </tr> <tr> <td>D9</td> <td>CENTER LEVEL -</td> <td>CENTER LEVEL +</td> <td>REAR LEVEL -</td> <td>REAR LEVEL +</td> </tr> <tr> <td>D10</td> <td>—</td> <td>—</td> <td>—</td> <td>—</td> </tr> <tr> <td>D11</td> <td>—</td> <td>—</td> <td>—</td> <td>—</td> </tr> <tr> <td>D12</td> <td>V-AUX</td> <td>VCR2</td> <td>VCR1</td> <td>LD/TV</td> </tr> <tr> <td>D13</td> <td>TAPE MONITOR</td> <td>TUNER</td> <td>CD</td> <td>PHONO</td> </tr> </tbody> </table>		K1	K2	K3	K4	D3	—	—	—	—	D4	PRO LOGIC	ENHANCED	CONCERT VIDEO	MONO MOVIE	D5	STADIUM	DISCO	ROCK CONCERT	CONCERT HALL	D6	—	—	—	—	D7	—	—	—	—	D8	EFFECT	CENTER MODE	DELAY TIME -	DELAY TIME +	D9	CENTER LEVEL -	CENTER LEVEL +	REAR LEVEL -	REAR LEVEL +	D10	—	—	—	—	D11	—	—	—	—	D12	V-AUX	VCR2	VCR1	LD/TV	D13	TAPE MONITOR	TUNER	CD	PHONO
	K1	K2	K3			K4																																																											
D3	—	—	—			—																																																											
D4	PRO LOGIC	ENHANCED	CONCERT VIDEO			MONO MOVIE																																																											
D5	STADIUM	DISCO	ROCK CONCERT	CONCERT HALL																																																													
D6	—	—	—	—																																																													
D7	—	—	—	—																																																													
D8	EFFECT	CENTER MODE	DELAY TIME -	DELAY TIME +																																																													
D9	CENTER LEVEL -	CENTER LEVEL +	REAR LEVEL -	REAR LEVEL +																																																													
D10	—	—	—	—																																																													
D11	—	—	—	—																																																													
D12	V-AUX	VCR2	VCR1	LD/TV																																																													
D13	TAPE MONITOR	TUNER	CD	PHONO																																																													
34	P26	K3	I																																																														
35	P25	K2	I																																																														
36	P24	K1	I																																																														
37	P23	D13	O	Fluorescent character display tube anode drive signal & Key scan digit																																																													
38	P22	D12	O																																																														
39	P21	D11	O																																																														
40	P20	D10	O																																																														
41	P17	D9	O																																																														
42	P16	D8	O																																																														
43	P15	D7	O																																																														
44	P14	D6	O																																																														
45	P13	D5	O																																																														
46	P12	D4	O																																																														
47	P11	D3	O																																																														
48	P10	D2	O																																																														
49	P07	D1	O																																																														
50	P06	S15	O	Fluorescent character display tube grid drive signal	H : ON																																																												
51	P05	S14	O		H : ON																																																												
52	P04	S13	O		H : ON																																																												
53	P03	S12	O		H : ON																																																												
54	P02	S11	O		H : ON																																																												
55	P01	S10	O		H : ON																																																												
56	P00	S9	O		H : ON																																																												
57	P37	S8	O		H : ON																																																												
58	P36	S7	O		H : ON																																																												
59	P35	S6	O		H : ON																																																												
60	P34	S5	O		H : ON																																																												
61	P33	S4	O		H : ON																																																												
62	P32	S3	O		H : ON																																																												
63	P31	S2	O		H : ON																																																												
64	P30	S1	O		H : ON																																																												

IC17 : YSS203B

Digital Dolby Pro Logic Decoder with Auto Input Balance

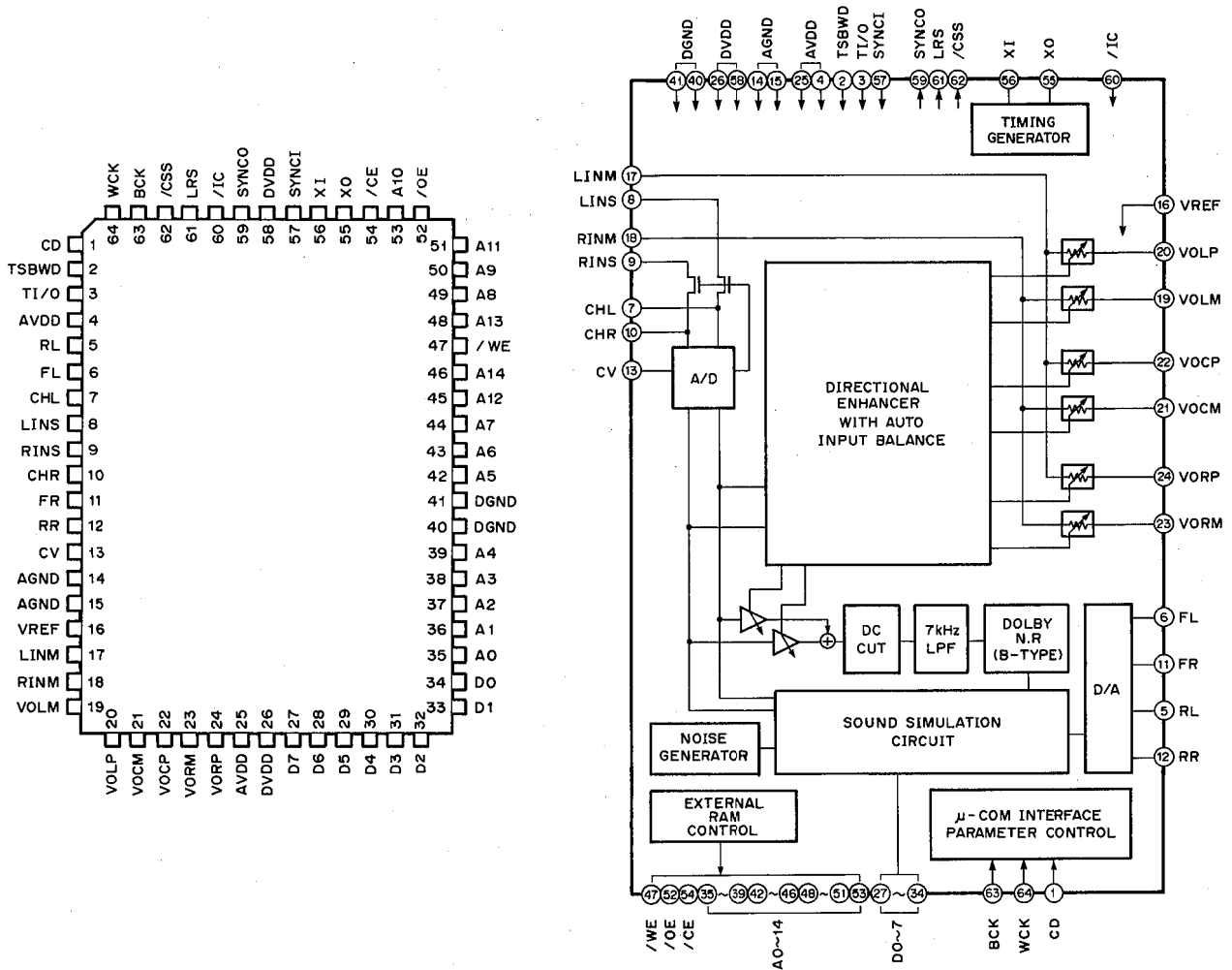

No.	Name	I/O	Function
1	CD	I/O	Serial data of parameter data input
2	TSBWD	Ic	LSI test terminal Normally connected to DVDD terminal
3	TI/O	Ic	LSI test terminal Normally connected to DVDD terminal
4	AVDD	A—	+5V power supply (D/A, A/D section)
5	RL	AO	RL channel D/A output
6	FL	AO	FL channel D/A output
7	CHL	A—	LINS input Sample/hold Capacitor external terminal
8	LINS	AI	L channel A/D input
9	RINS	AI	R channel A/D input
10	CHR	A—	RINS input Sample/hold Capacitor external terminal
11	FR	AO	FR channel D/A output
12	RR	AO	RR channel D/A output
13	CV	AO	A/D, multiplying DAC center voltage
14	AGND	A—	Ground (D/A, A/D section)
15	AGND	A—	Ground (Multiplying DAC section)
16	VREF	AI	Multiplying DAC reference voltage input
17	LINM	AI	L channel Multiplying DAC input
18	RINM	AI	R channel Multiplying DAC input
19	VOLM	AO	L channel operation amplifier, connected to (-) terminal
20	VOLP	AO	L channel operation amplifier, connected to (+) terminal

No.	Name	I/O	Function
21	VOCM	AO	C channel operation amplifier, connected to (-) terminal
22	VOCP	AO	C channel operation amplifier, connected to (+) terminal
23	VORM	AO	R channel operation amplifier, connected to (-) terminal
24	VORP	AO	R channel operation amplifier, connected to (+) terminal
25	AVDD	A—	+5V power supply (multiplying DAC section)
26	DVDD	—	+5V power supply (digital section)
27	D7	I/Ot	External delay RAM data terminal
28	D6	I/Ot	External delay RAM data terminal
29	D5	I/Ot	External delay RAM data terminal
30	D4	I/Ot	External delay RAM data terminal
31	D3	I/Ot	External delay RAM data terminal
32	D2	I/Ot	External delay RAM data terminal
33	D1	I/Ot	External delay RAM data terminal
34	D0	I/Ot	External delay RAM data terminal
35	A0	O	External data RAM address terminal
36	A1	O	External data RAM address terminal
37	A2	O	External data RAM address terminal
38	A3	O	External data RAM address terminal
39	A4	O	External data RAM address terminal
40	DGND	—	Ground (digital section)
41	DGND	—	Ground (digital section)
42	A5	O	External data RAM address terminal
43	A6	O	External data RAM address terminal
44	A7	O	External data RAM address terminal
45	A12	O	External data RAM address terminal
46	A14	O	External data RAM address terminal
47	/WE	O	External delay RAM write enable terminal
48	A13	O	External delay RAM address terminal
49	A8	O	External delay RAM address terminal
50	A9	O	External delay RAM address terminal
51	A11	O	External delay RAM address terminal
52	/OE	O	External delay RAM output enable terminal
53	A10	O	External delay RAM address terminal
54	/CE	O	External delay RAM chip enable terminal
55	XO	O	Crystal oscillator connecting terminal
56	XI	I	Crystal oscillator connecting terminal
57	SYNCI	It	Test terminal for system synchronization, normally connected to DVDD
58	DVDD	—	+5V power supply (digital section)
59	SYNCO	O	Test terminal for system synchronization, normally unconnected
60	/IC	Ics	Initial clear terminal (Power ON resetting is necessary)
61	LRS	O	External automatic input balance terminal, normally unconnected
62	/CSS	O	External automatic input balance terminal, normally unconnected
63	BCK	I _{ts}	Bit clock for parameter data input
64	WCK	I _{ts}	Word clock for parameter data input

Note : Letters used in the above I/O column represent as follows.

I : Input terminal O : Output terminal t : TTL level
c : CMOS level s : Schmidt input A : Analog terminal

■ DISPLAY DATA

● V901 : 13-BT-137(VS550600)

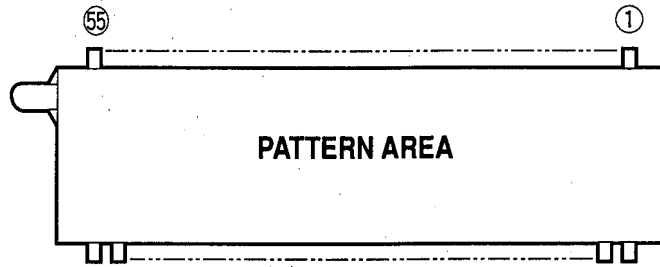

● PIN CONNECTION

Pin No.	55	54	53	52	51	50	49	48	47	46	45	44	43	42	41	40	39	38	37
Connection	F2	F2	NP	NP	P1	P2	P3	P4	P5	P6	P7	P8	P9	P10	P11	P12	P13	P14	P15
Pin No.	36	35	34	33	32	31	30	29	28	27	26	25	24	23	22	21	20	19	18
Connection	P16	NC	NC	NC	NC	NC	NC	NC	NC	NC	NC	NC	NC	NC	NC	NC	NC	NC	NC
Pin No.	17	16	15	14	13	12	11	10	9	8	7	6	5	4	3	2	1		
Connection	13G	12G	11G	10G	9G	8G	7G	6G	5G	4G	3G	2G	1G	NP	NP	F1	F1		

Note 1) F1, F2 Filament 3) NC No Connection 5) 1G~13G Grid
 2) NP No Pin 4) P1~P16 Datum Line

● GRID ASSIGNMENT

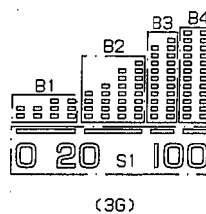
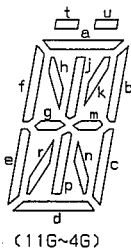
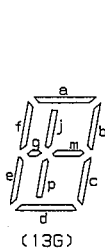
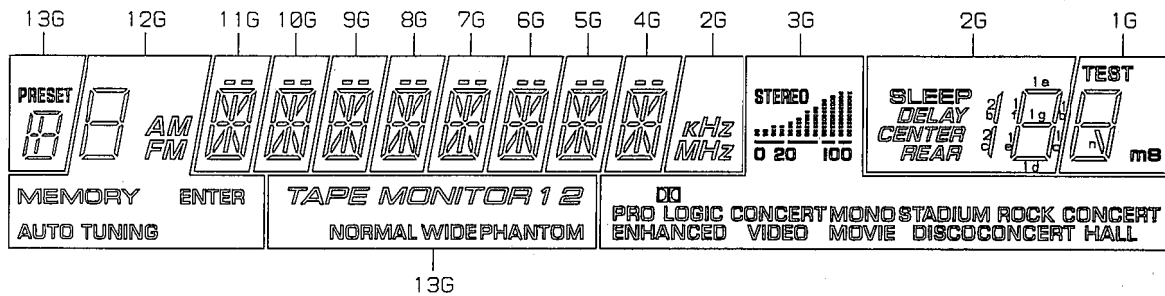

● ANODE CONNECTION

	13G	12G	11G	10G	9G	8G	7G	6G	5G	4G	3G	2G	1G
P1	a	a	a	a	a	a	a	a	a	a	CONCERT HALL	1a	a
P2	b, c	b	b	b	b	b	b	b	b	b	ROCK CONCERT	1b	b
P3	d	c	c	c	c	c	c	c	c	c	DISCO	1c	c
P4	e, f	d	d	d	d	d	d	d	d	d	STADIUM	1d	d
P5	g	e	e	e	e	e	e	e	e	e	MONO MOVIE	1e	e
P6	j, p	f	f	f	f	f	f	f	f	f	CONCERT VIDEO	1f	f
P7	m	g	g	g	g	g	g	g	g	g	PRO LOGIC	1g	g
P8	PRESET	ENTER	h	h	h	h	h	h	h	h	ENHANCED	2b, 2c	n
P9	NORMAL	AM	j	j	j	j	j	j	j	j	STEREO	kHz	TEST
P10	WIDE	FM	k	k	k	k	k	k	k	k	S1	MHz	mS
P11	PHANTOM	MEMORY	m	m	m	m	m	m	m	m	B1	DELAY	—
P12	TAPE MONITOR	AUTO TUNING	n	n	n	n	n	n	n	n	B2	CENTER	—
P13	1	—	p	p	p	p	p	p	p	p	B3	REAR	—
P14	2	—	r	r	r	r	r	r	r	r	B4	SLEEP	—
P15	—	—	t	t	t	t	t	t	t	t	—	—	—
P16	—	—	u	u	u	u	u	u	u	u	—	—	—

PRINTED CIRCUIT BOARD (Foil side)

Note) Mounting of C550, 551 (B, G only) shown as below.

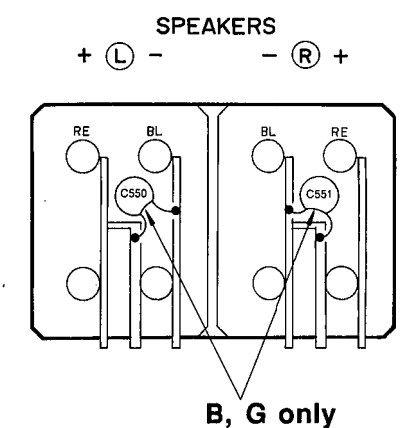
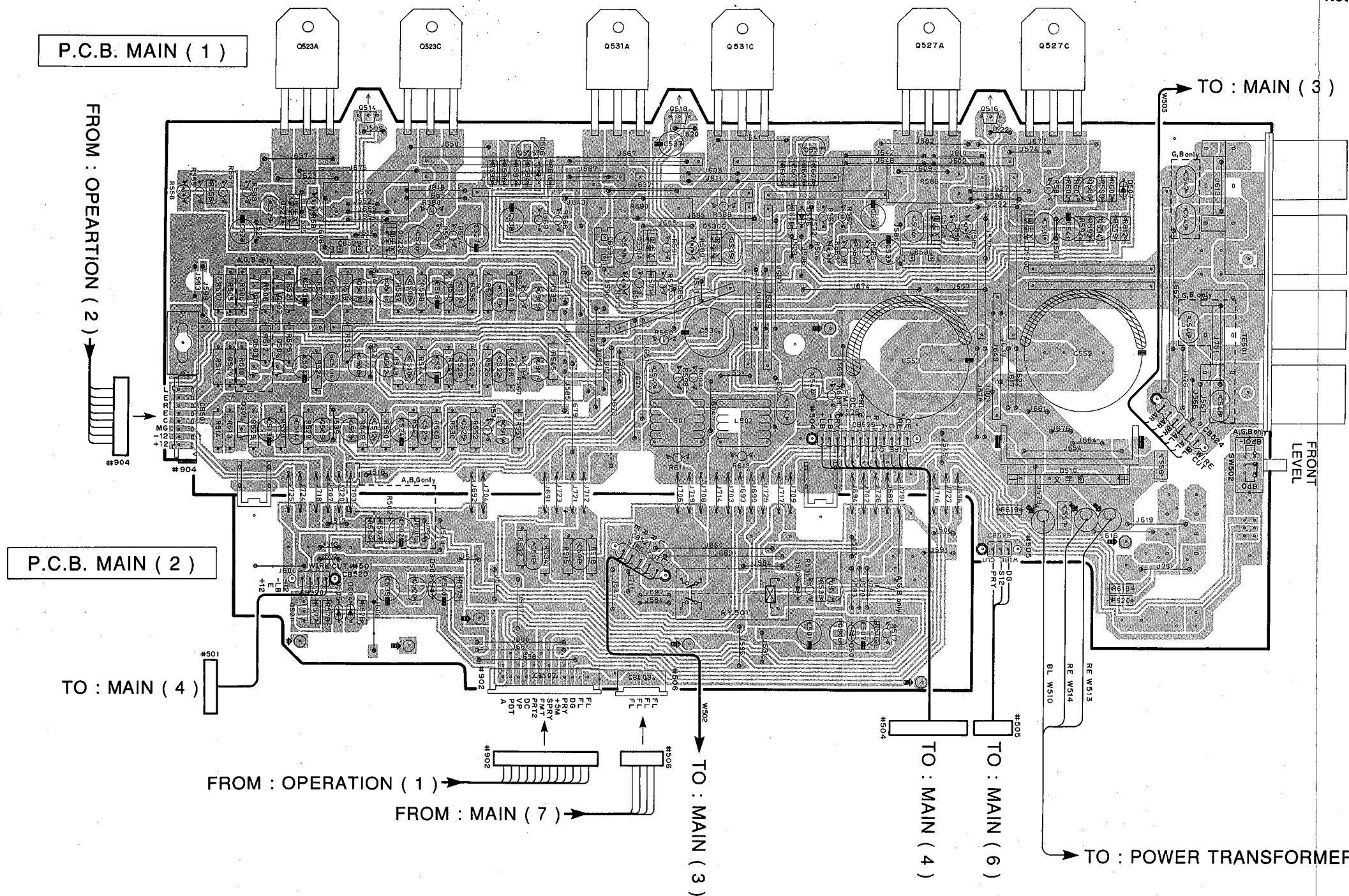

Semiconductor Location

Ref. No.	Location
Q501	B2
Q502	B2
Q503	B3
Q504	B3
Q505	B3
Q506	D4
Q507	B2
Q508	B3
Q509	B3
Q510	D3
Q511	B2
Q512	B3
Q513	B3
Q514	B1
Q515	C2
Q516	E1
Q517	C3
Q518	D1
Q519	C3
Q520	B3
Q521	B4
Q522A	B2
Q522C	B2
Q523A	B1
Q523C	B1
Q526A	E2
Q526C	E2
Q527A	E1
Q527C	E1
Q530A	C2
Q530C	D2
Q531A	C1
Q531C	D1
Q534	E2
Q535	C2
Q536	E2
Q537	D2

Confirmation of Idling Current

- 1) No signal applied.
- 2) Non-loaded condition.
- 3) Aging is not necessary.

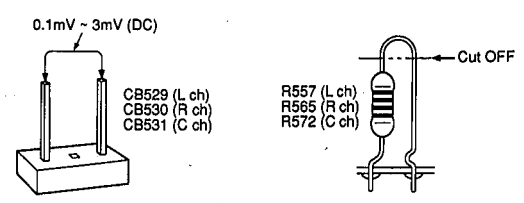

Item	Test Point	Rating (DC)	Note
FRONT L	CB529	0.3mV~3mV	If the measured voltage exceeds 3.1mV, cut the lead wires of R557(L ch), R565(R ch) and R572(C ch) and then check again if each measured value satisfies the rating.
FRONT R	CB530		
CENTER	CB531		

Note)
 • If R557(L ch), R565(R ch) and R572(C ch) have already been cut off and idling current does not flow, reconnect R557(L ch), R565(R ch) and R572(C ch).
 • Q514, Q516 and Q518 are transistors for temperature correction.
 Apply silicone grease to contact surface with the heat sink.

PRINTED CIRCUIT BOARD (Foil side)

1

2

3

4

5

6

A

B

C

D

E

F

G

H

P.C.B. MAIN (3)

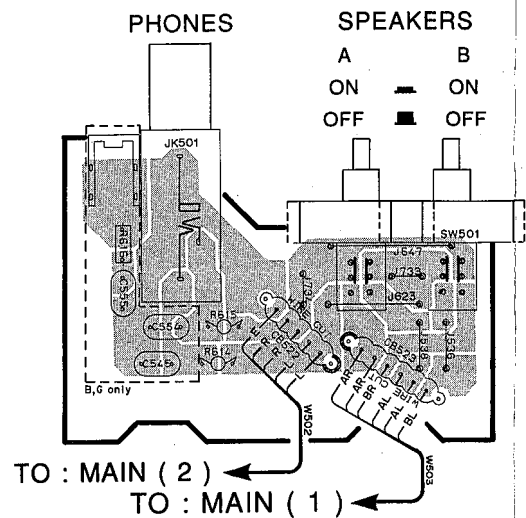

P.C.B. OPERATION (2)

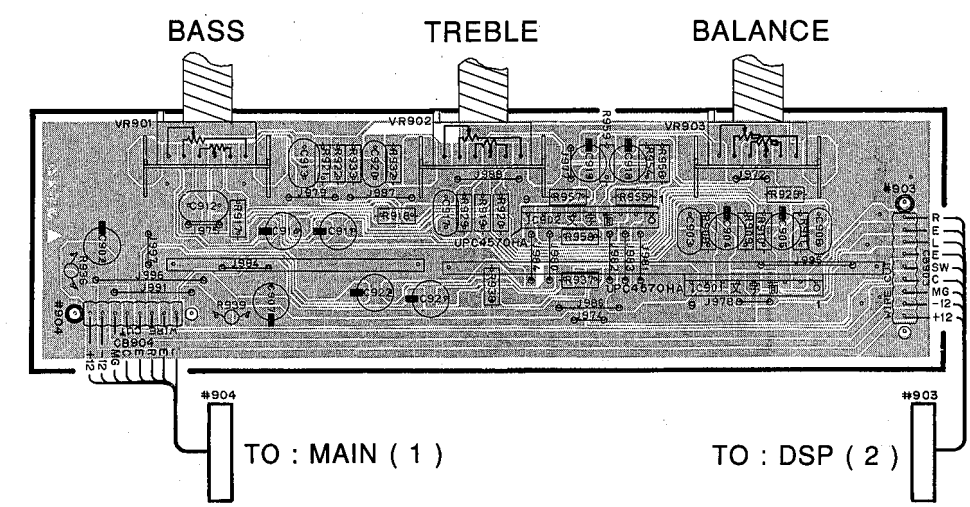

P.C.B. MAIN (5)

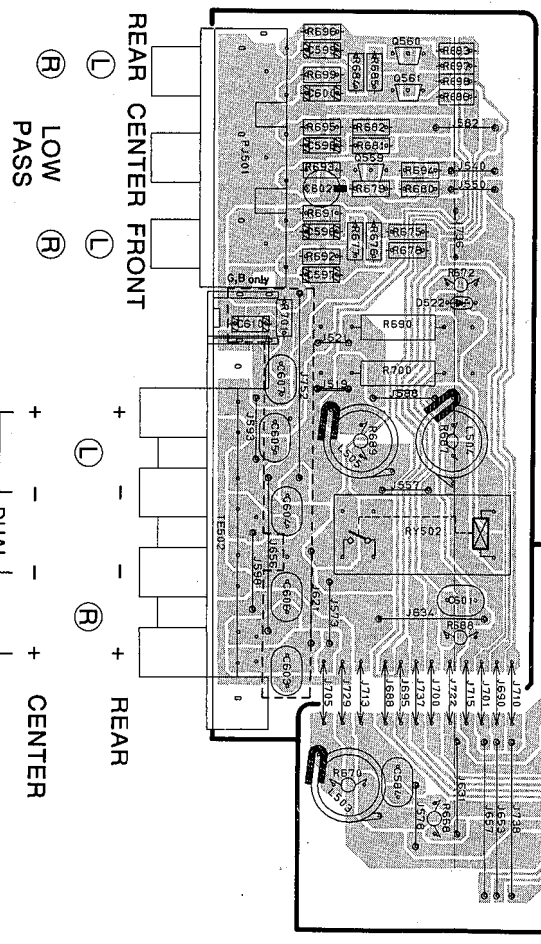

P.C.B. MAIN (4)

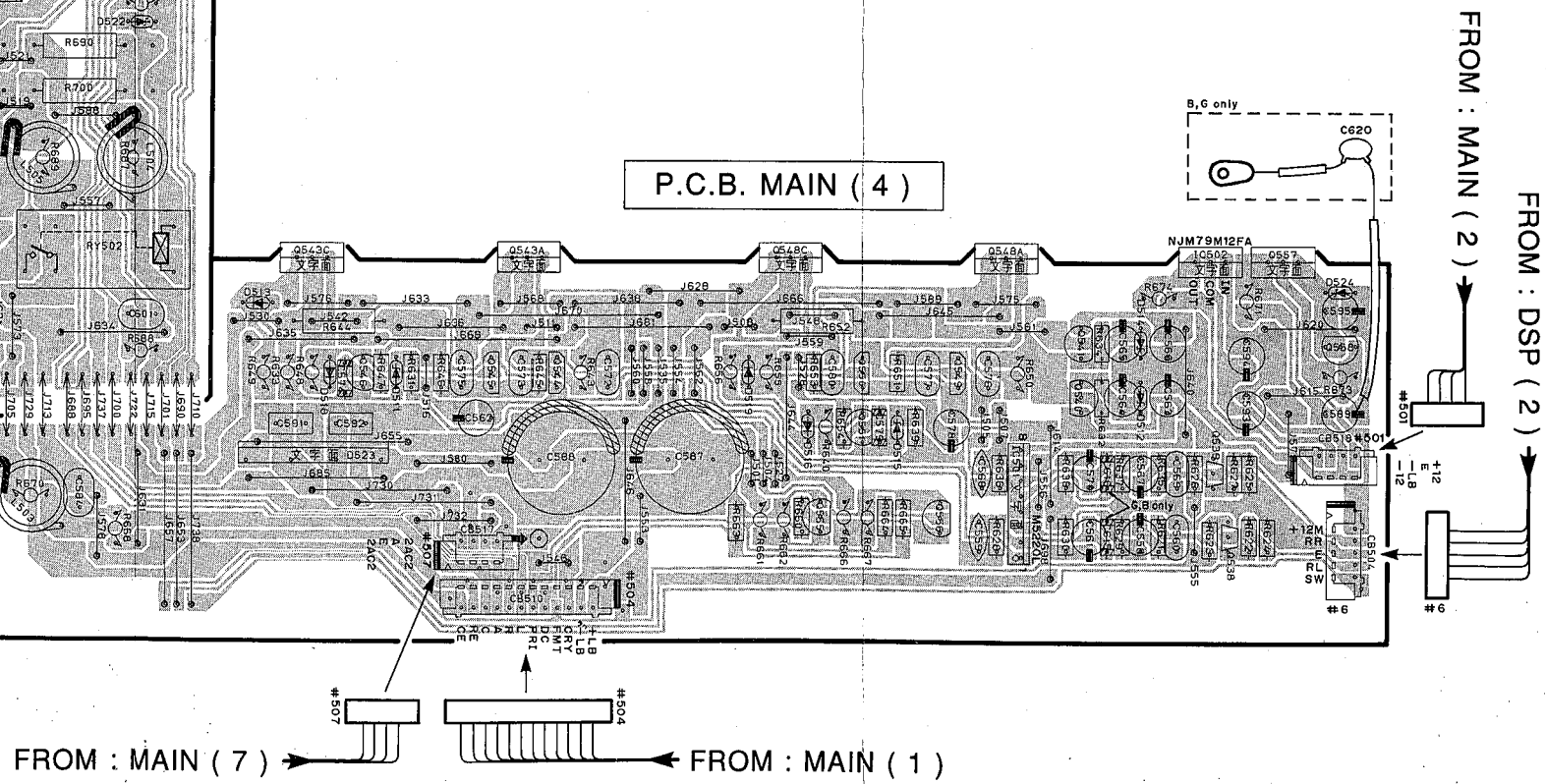

● Semiconductor Location

Ref. No.	Location
IC 501	E5
IC 502	E5
IC 901	G2
IC 902	G2
Q538	E5
Q539	E5
Q540	E5
Q541	E5
Q543A	D4
Q543C	C4
Q544	D5
Q545	C5
Q546	C5
Q548A	E4
Q548C	D4
Q549	E5
Q550	D5
Q551	D5
Q555	D5
Q556	E5
Q557	F4
Q558	F5
Q559	B3
Q560	B3
Q561	B3

PRINTED CIRCUIT BOARD (Foil side)

① : TEST POINT WAVEFORMS (See page 26)

● Semiconductor Location

Ref. No.	Location
IC 1	G2
IC 2	F2
IC 3	F3
IC 4	F3
IC 5	E3
IC 6	F3
IC 7	E2
IC 8	D2
IC 9	F2
IC 10	D2
IC 11	E3
IC 12	E3
IC 13	E3
IC 14	E2
IC 15	E2
IC 16	F3
IC 17	D3
IC 18	D3
IC 19	D3
IC 20	D2
IC 21	C2
Q 1	C2
Q 2	C2

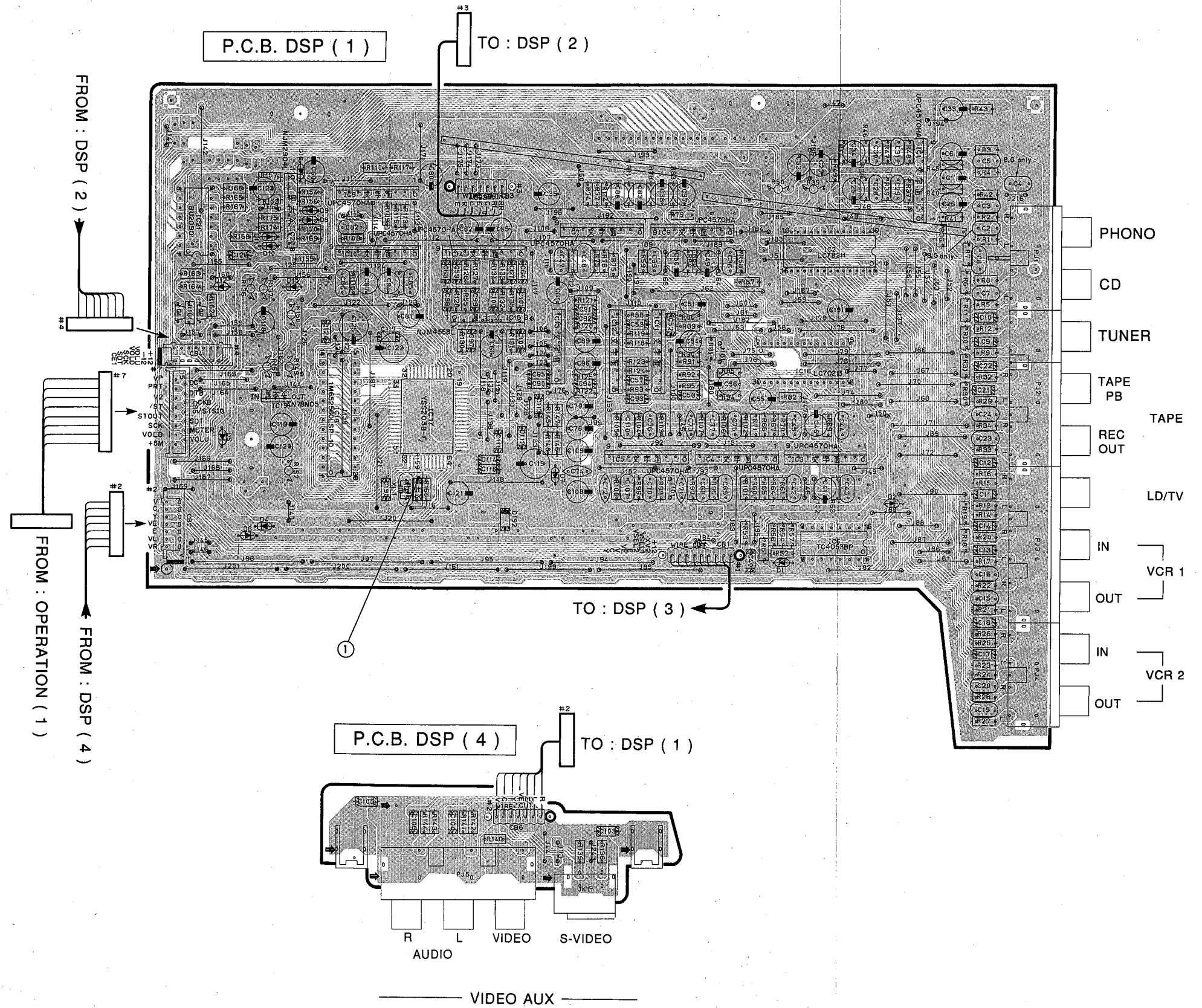

■ PRINTED CIRCUIT BOARD (Foil side)

② and ③ : TEST POINT WAVEFORMS (See page 28)

● Semiconductor Location

Ref. No.	Location
IC 22	C4
IC 23	C5
IC 24	C5
IC 25	C6
IC 26	C5
IC 27	D5
IC 28	B5
IC 29	F5
IC 30	F5
IC 31	F4
IC 32	F4
IC903	E2
Q 3	F4
Q 4	F4
Q 5	F4
Q 6	F4
Q 7	F5
Q 8	F5

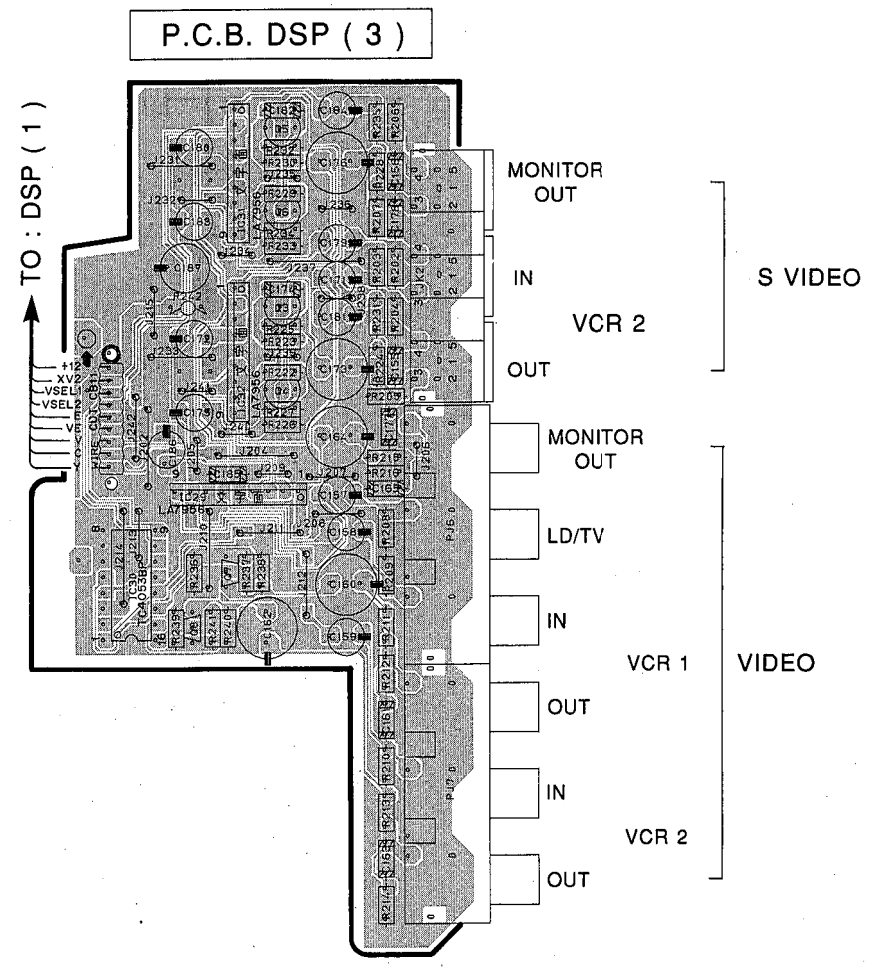
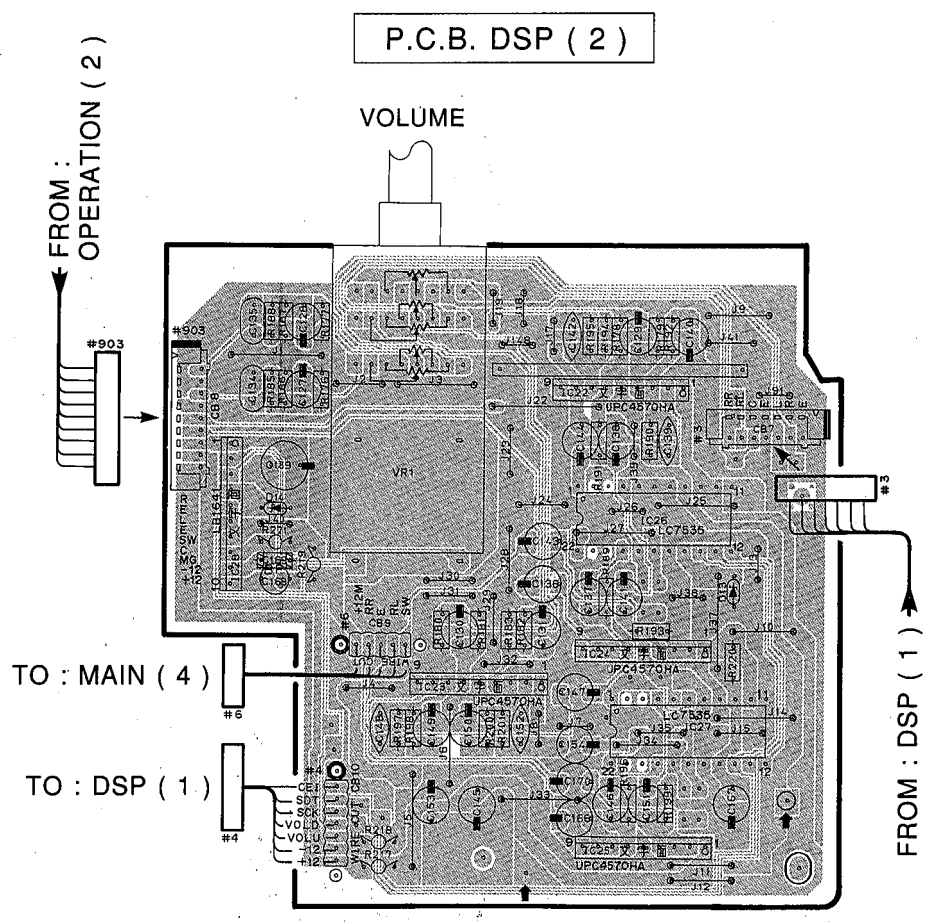
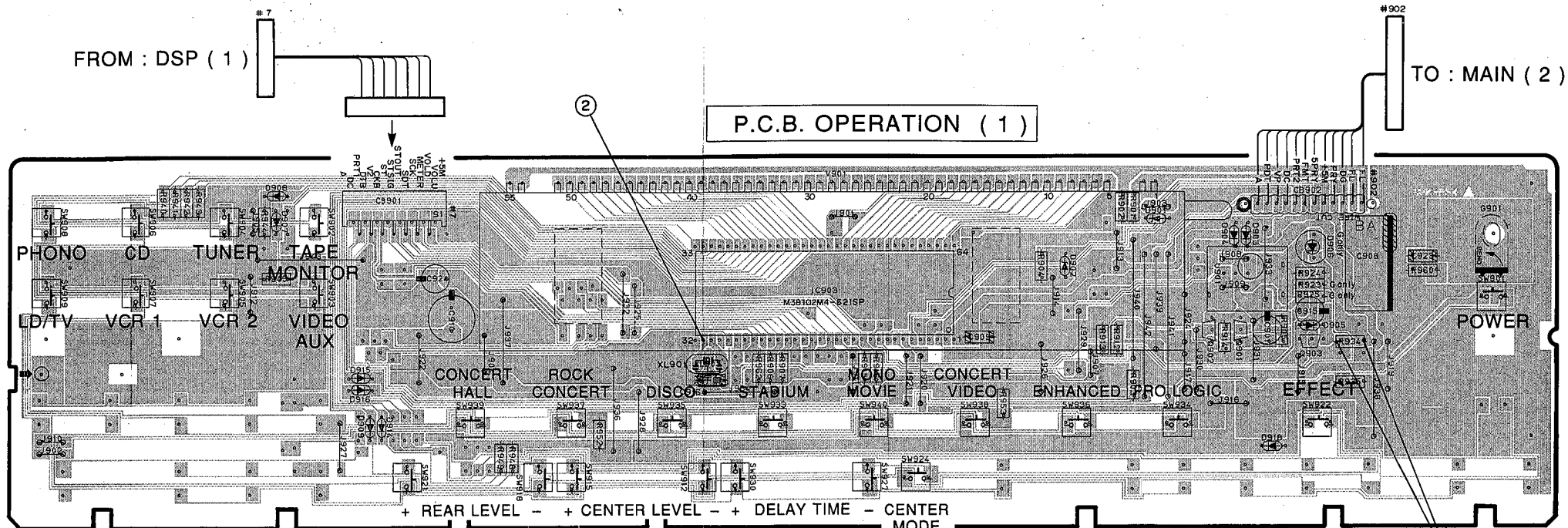

1

2

3

4

5

■ BLOCK DIAGRAM

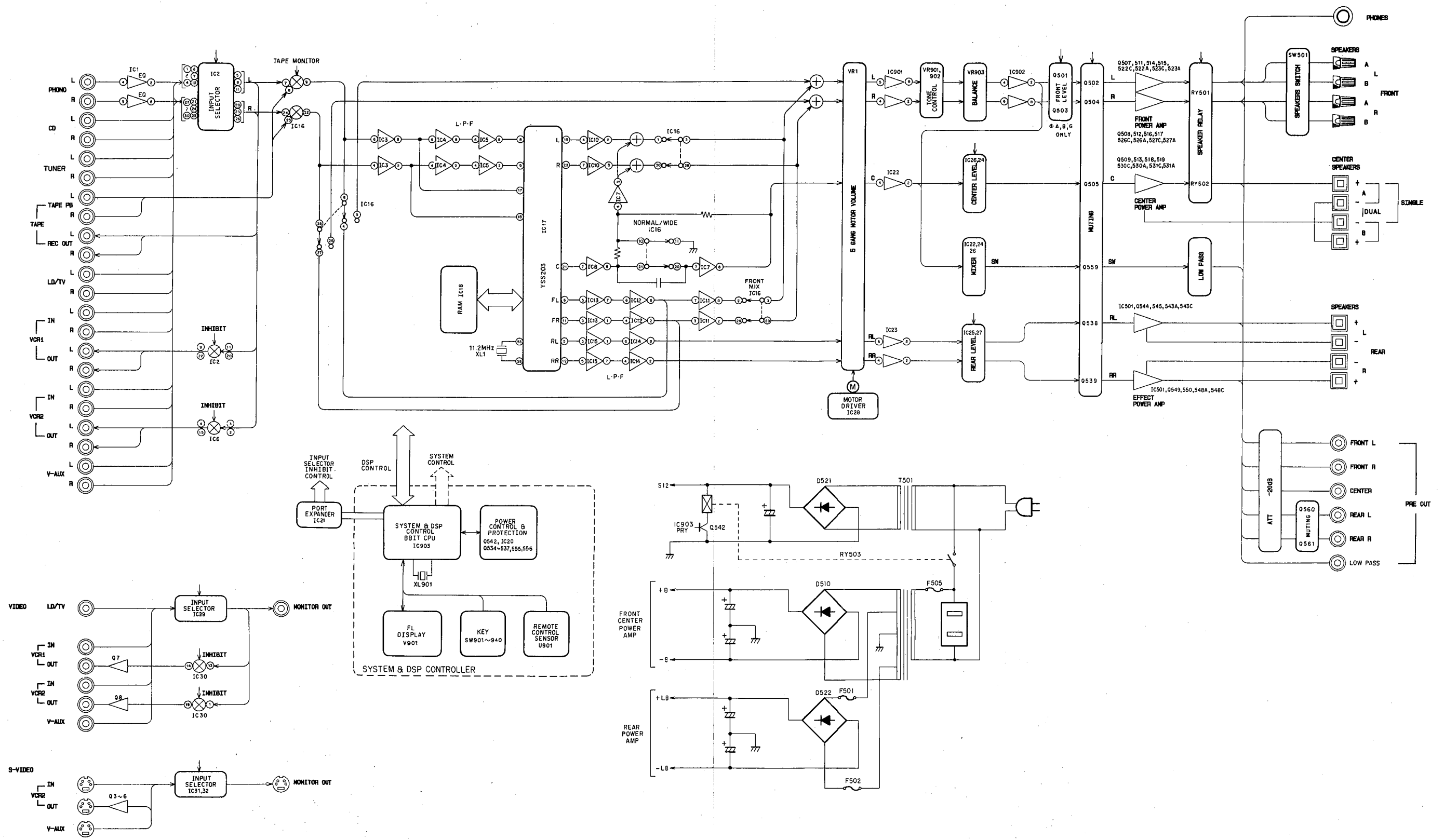

IC BLOCKS

IC1, 3~5, 7~12, 14, 22~25 : μ PC4570HA

IC901, 902 : μ PC4570HA

Dual OP-Amp

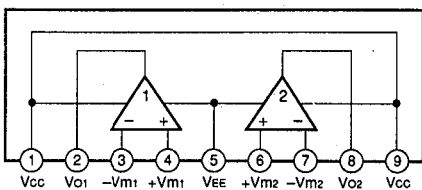

IC20 : NJM2904L

IC13, 15 : NJM4558L

IC501 : M5220L

Dual OP-Amp

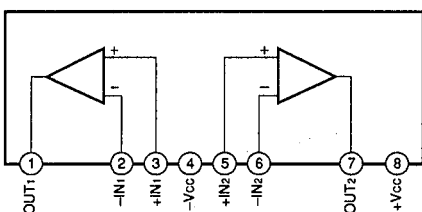

IC29, 31, 32 : LA7956

Video Switch

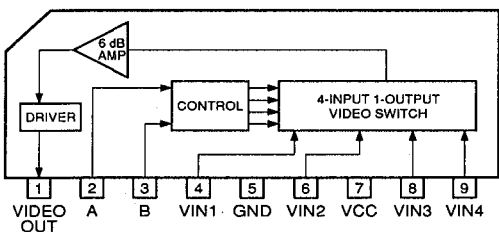

IC28 : LB1641

Motor Driver

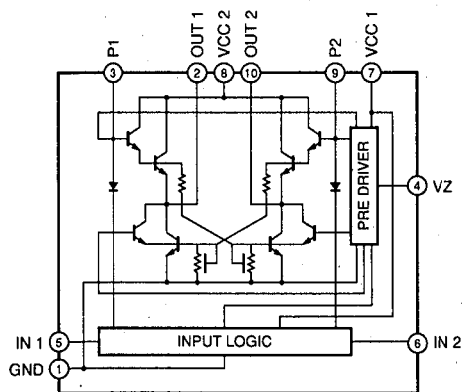

IC2 : LC78211

Analog Function Switch

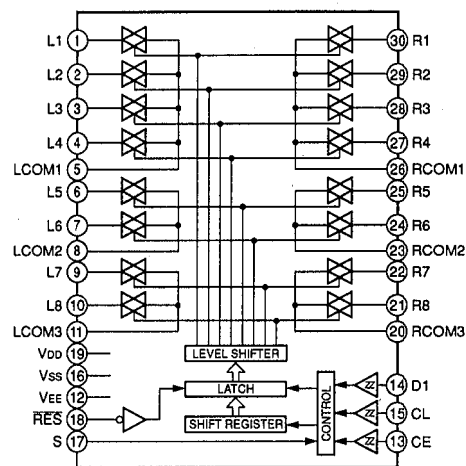

IC16 : LC78213

Analog Function Switch

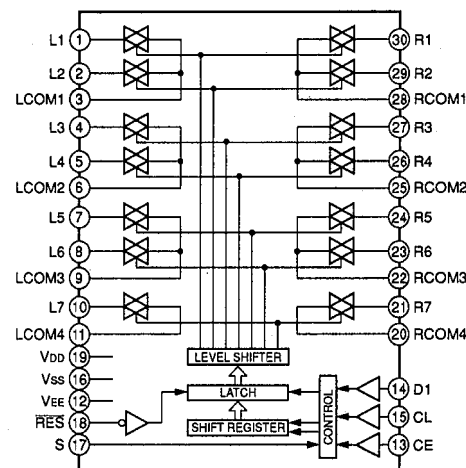

IC26, 27 : LC7535

Electric Controlled Volume

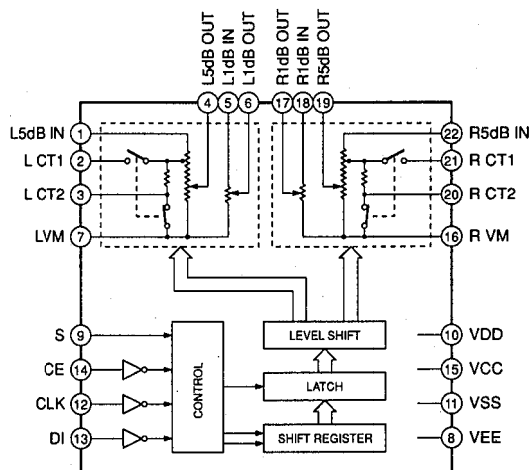

IC18 : HM65256BLSP-10
32768-word x 8 bit High Speed Pseudo Static RAM

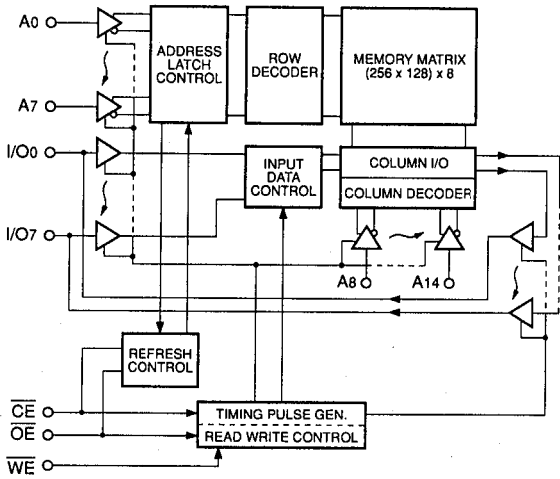
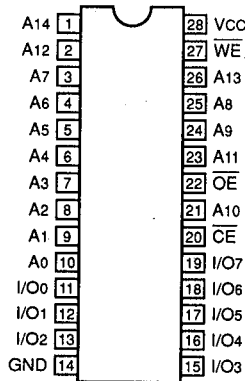

IC6, 30 : TC4053BP
Triple 2-Channel Multiplexer/Demultiplexer

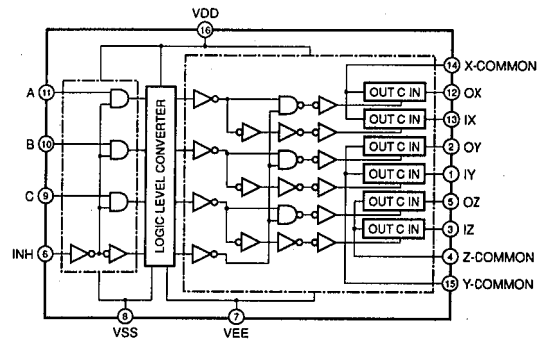

INHIBIT (Pin 6)	CONTROL INPUTS			"ON" CHANNEL		
	C (Pin 9)	B (Pin 10)	A (Pin 11)	0X (Pin 12), 0Y (Pin 2), 0Z (Pin 5)	1X (Pin 13), 1Y (Pin 1), 1Z (Pin 3)	2X (Pin 14), 2Y (Pin 4), 2Z (Pin 6)
L	L	L	L	0X, 0Y, 0Z	1X, 1Y, 1Z	2X, 2Y, 2Z
L	L	L	H	1X, 0Y, 0Z	0X, 1Y, 0Z	2X, 1Y, 1Z
L	L	H	L	0X, 1Y, 0Z	1X, 1Y, 0Z	0X, 0Y, 1Z
L	L	H	H	1X, 0Y, 1Z	0X, 1Y, 1Z	1X, 1Y, 1Z
L	H	L	L	0X, 0Y, 1Z	1X, 0Y, 1Z	0X, 1Y, 1Z
L	H	L	H	1X, 0Y, 1Z	0X, 1Y, 1Z	1X, 1Y, 1Z
L	H	H	L	0X, 1Y, 1Z	1X, 1Y, 1Z	0X, 0Y, 1Z
L	H	H	H	1X, 1Y, 1Z	0X, 0Y, 1Z	1X, 1Y, 1Z
H	*	*	*	NOTE		

* Don't Care

IC21 : BU2090
Serial In/Parallel Out Driver

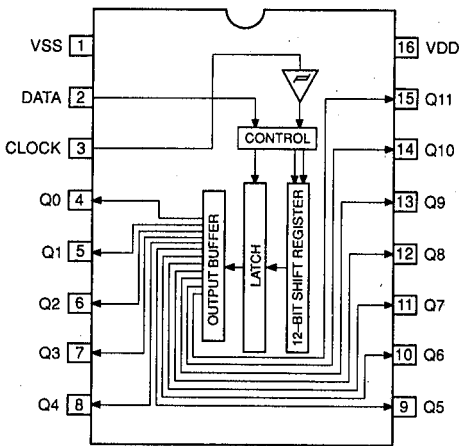

No.	Port	Name	Function	Logic
1	VSS		GND	
2	DATA		Data in	
3	CLK		Clock in	
4	Q0	STREQ	Stop request (N.C.)	
5	Q1	CE7000	Chip enable LM7000 (N.C.)	
6	Q2	/MONO	Mono out (N.C.)	L:MONO
7	Q3	TMUTE	Tuner mute (N.C.)	H:ON
8	Q4		N.C.	
9	Q5	DSEL	DSP serial select	H:DSP
10	Q6	CEDSP	Chip enable DSP	H:ON
11	Q7	CEISL	Chip enable LC7821/LC7823/LC7535	H:ON
12	Q8		N.C.	
13	Q9	V2INH	VCR2 not select H : not VCR2	L:VCR2
14	Q10	VSELA	Video selector A (LA7956)	
15	Q11	VSELB	Video selector B (LA7956)	
16	VDD		+5V	

Other IC's ● IC903 : M38102M4-621SP→See page 7
 ● IC17 : YSS203B→See page 9

SCHEMATIC DIAGRAM (DSP)

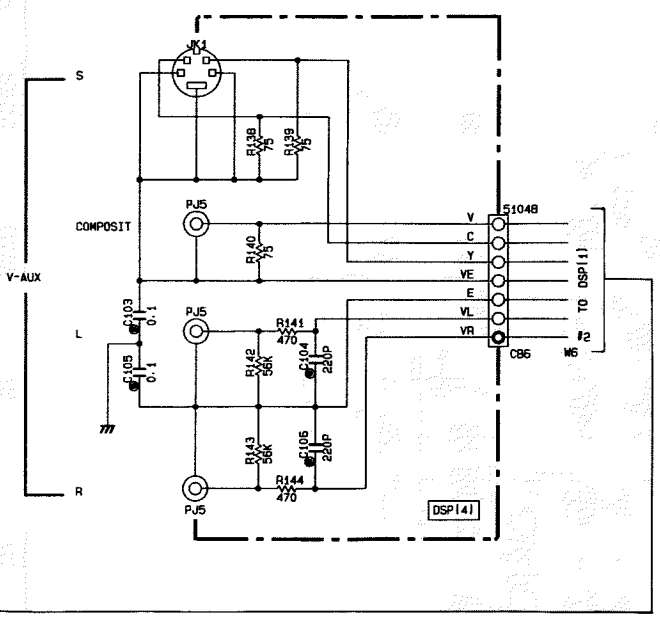

CAPACITOR

REMARKS	PARTS NAME
NO MARK ELECTROLYTIC CAPACITOR	⊗
TANTALUM CAPACITOR	⊗
NO MARK CERAMIC CAPACITOR	⊗
CERAMIC TUBULAR CAPACITOR	⊗
POLYESTER FILM CAPACITOR	⊗
POLYETHYLENE FILM CAPACITOR	⊗
MICA CAPACITOR	⊗
POLYPROPYLENE FILM CAPACITOR	⊗
SEMICONDUCTIVE CERAMIC CAPACITOR	⊗

RESISTOR

REMARKS	PARTS NAME
NO MARK CARBON FILM RESISTOR (P=5)	⊗
CARBON FILM RESISTOR (P=10)	⊗
METAL OXIDE FILM RESISTOR	⊗
METAL FILM RESISTOR	⊗
METAL PLATE RESISTOR	⊗
FIRE PROOF CARBON FILM RESISTOR	⊗
CEMENT MOLDED RESISTOR	⊗
SEMI VARIABLE RESISTOR	⊗
CHIP RESISTOR	⊗

Interchangeable Parts at Manufacture-Stage

Part No.	Reference Parts Number	Parts Name
A1	106-30	RESISTOR
A2	04-13-15-16	RESISTOR
A3	04-2	RESISTOR
A4	013-14	RESISTOR
A5	IC18	IC

Point ① (Pin 55 of IC 17)
 V : 2V/div H : 50ns/div
 DC range 1 : 1 prove

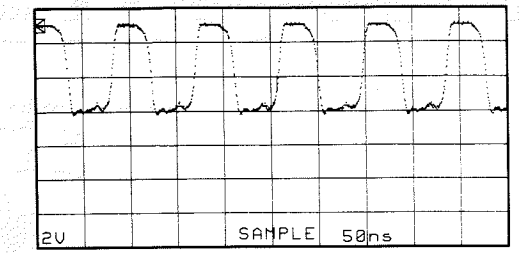

IC16 : LC78213

Case	10	21	8	23	7	24	5	26	4	27	2	29	1	30
1	SEL1	1	1	1	1	1	1	1	1	1	1	1	1	1
2	SEL2	1	1	1	1	1	1	1	1	1	1	1	1	1
3	SEL2	1	1	1	1	1	1	1	1	1	1	1	1	1
4	EFFECT OFF	1	1	1	1	1	1	1	1	1	1	1	1	1
5	TEST	1	1	1	1	1	1	1	1	1	1	1	1	1
6	PRO LOGIC	1	1	1	1	1	1	1	1	1	1	1	1	1
7	ENHANCED	1	1	1	1	1	1	1	1	1	1	1	1	1
8	DSP PROGRAM	1	1	1	1	1	1	1	1	1	1	1	1	1
Input	TAPE MONITOR	1	1	1	1	1	1	1	1	1	1	1	1	1
Input	EXACT	1	1	1	1	1	1	1	1	1	1	1	1	1

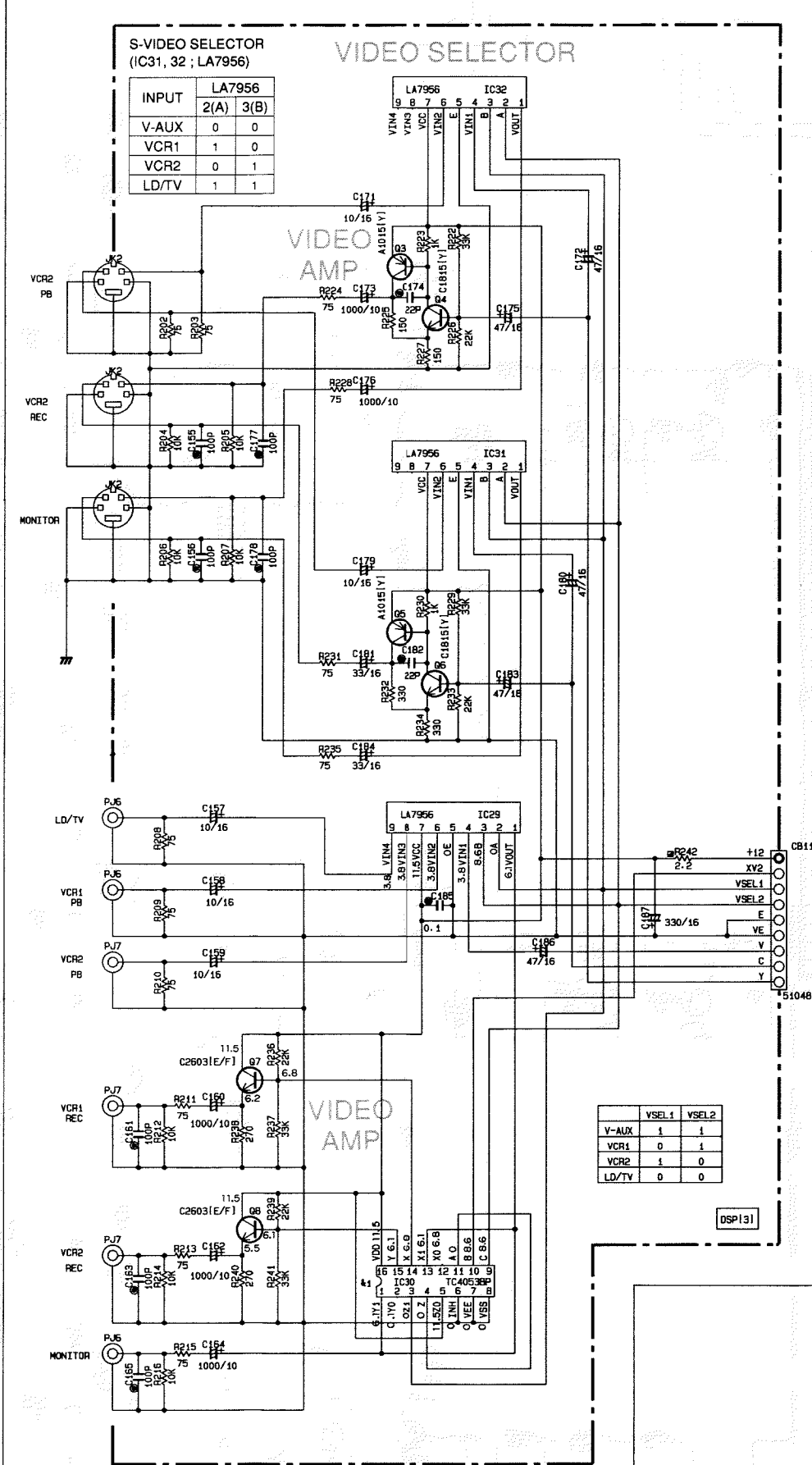
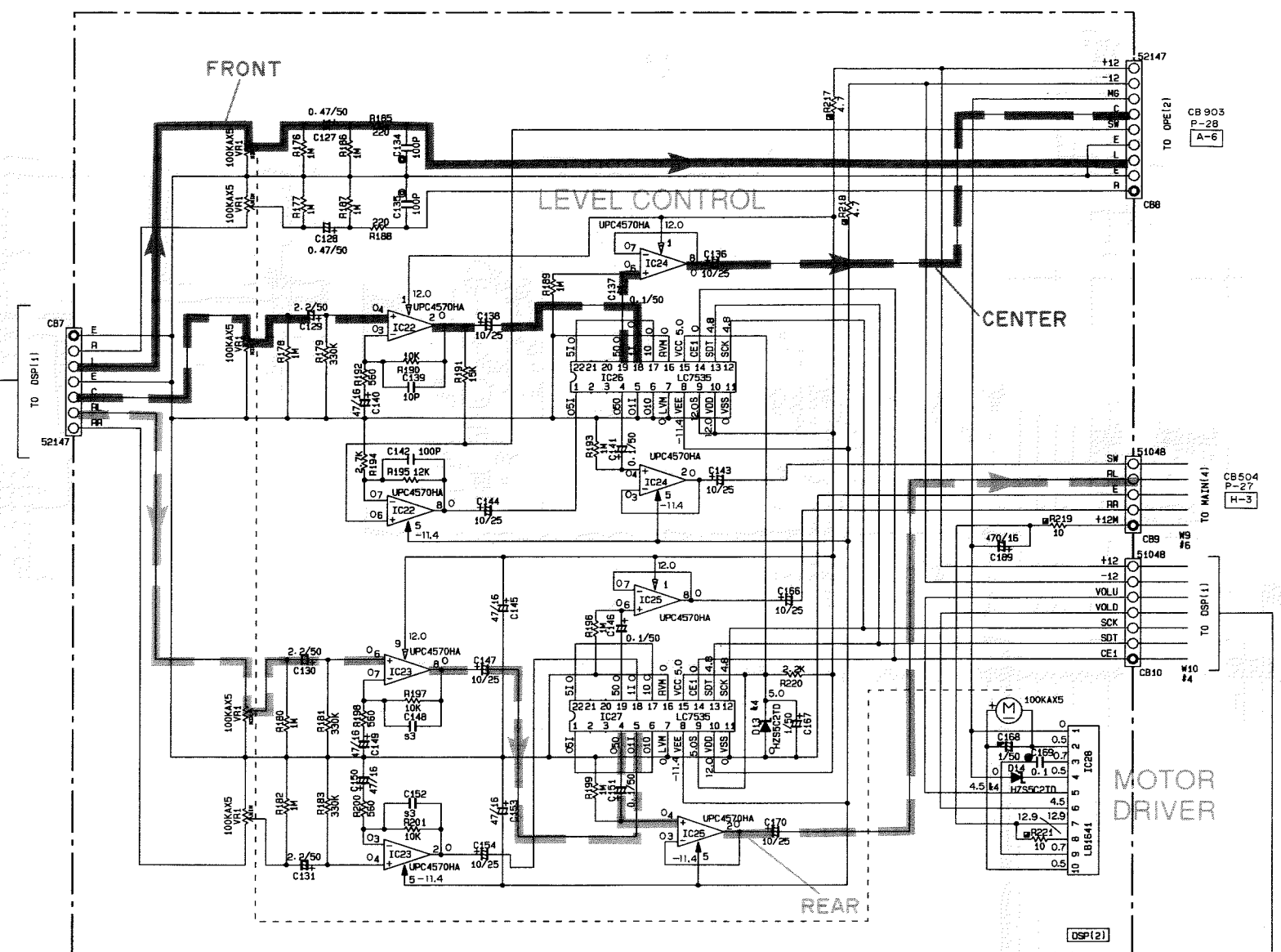
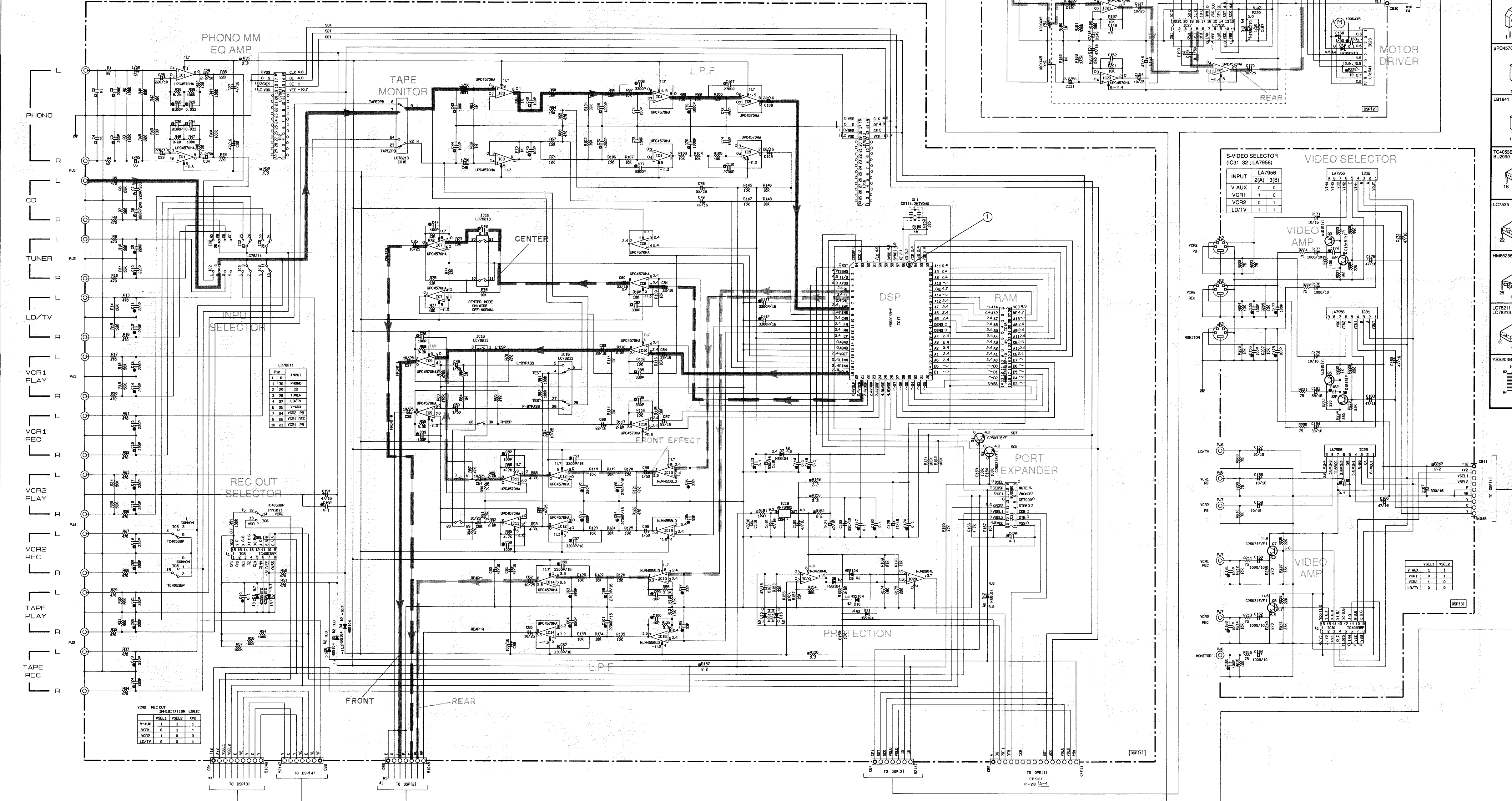

PIN CONNECTION DIAGRAM OF TRANSISTORS, DIODES AND ICs.

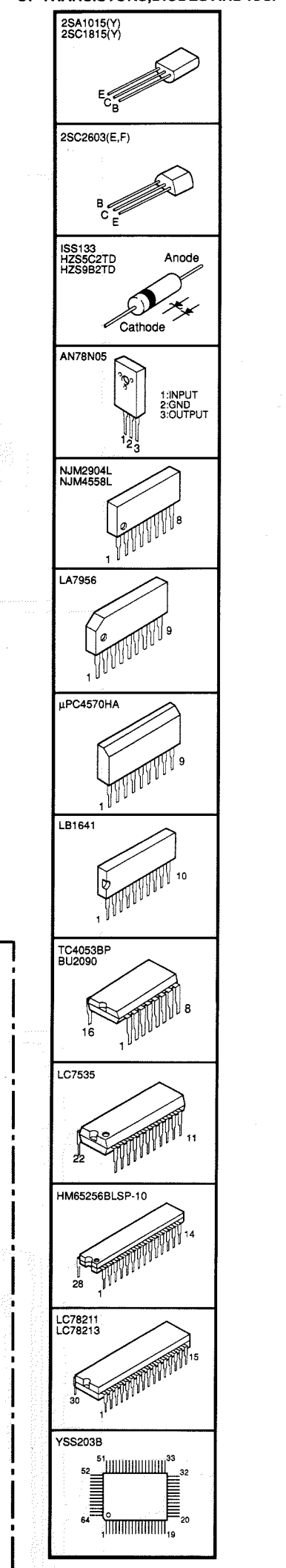

All voltage are measured with a 10MΩ/V DC electric volt meter.
 Components having special characteristics are marked Δ and must be replaced with parts having specifications equal to those originally installed.
 Schematic diagram is subject to change without notice.

SCHEMATIC DIAGRAM (OPERATION)

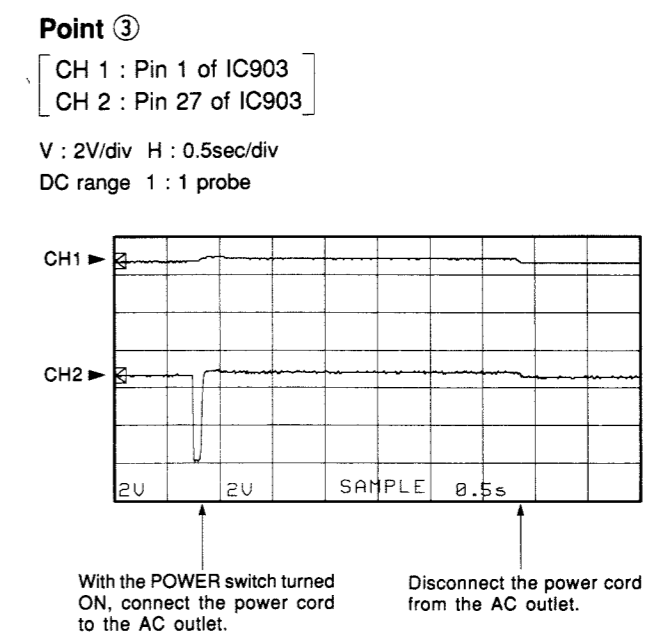
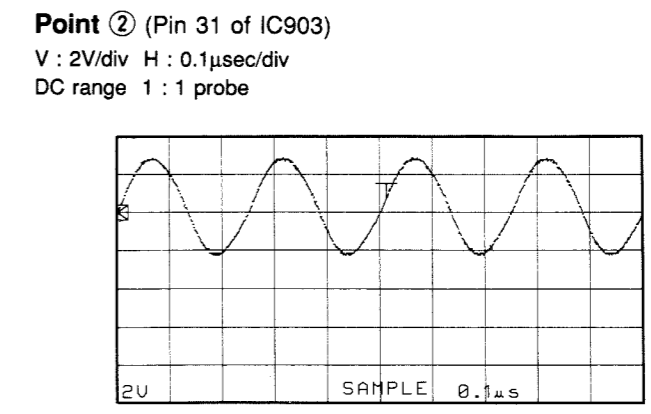
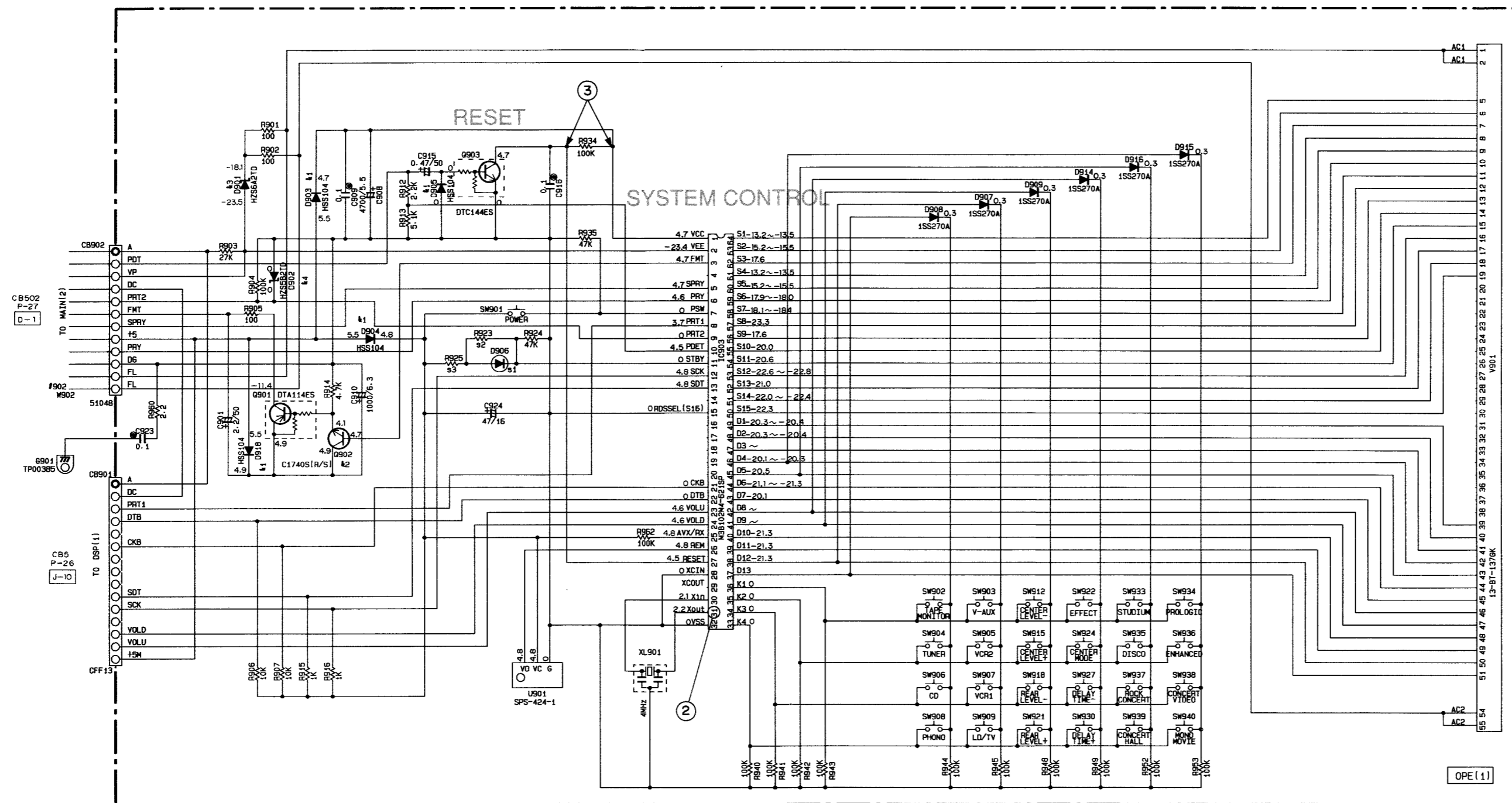

With the POWER switch turned ON, connect the power cord to the AC outlet.
 Disconnect the power cord from the AC outlet.

* This waveform is not available by pushing the power switch ON and OFF.

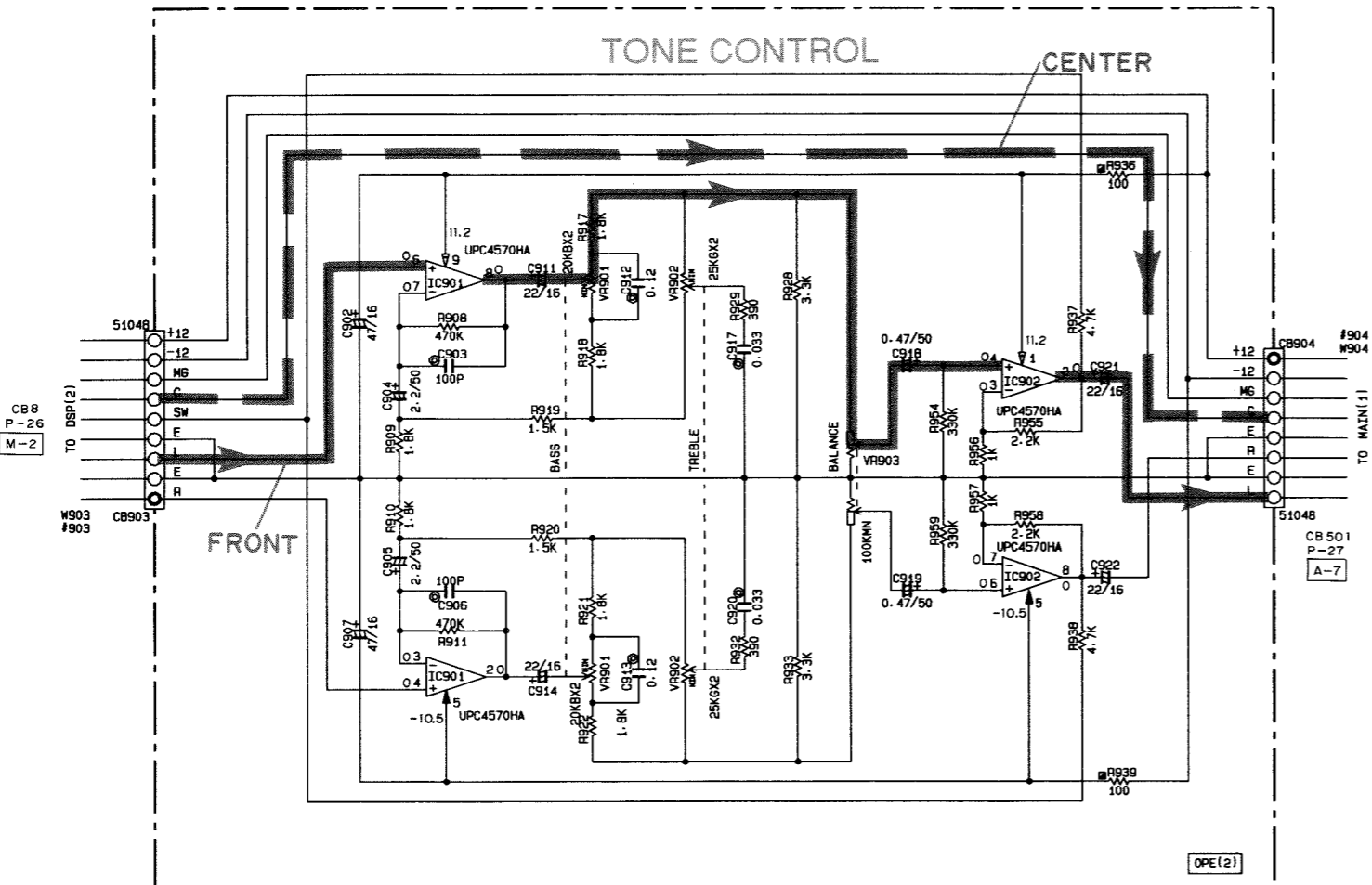

s	Circuit No.	J-R-A-B	G
1	D906	X	SLR-305VCA47
2	R923	X	33K
3	R925	X	220
PCB	V571090		V571100
PWB	X0053		X0053

Interchangeable Parts at Manufacture-Stage

Mark	Reference Parts Number	Parts Name
⊕1	D903-905-918	HSS104 1SS133 1SS176
⊕2	D902	2SC1740S1R/S1 2SC26031E/F1 2SC3311A1G/R/S1
⊕3	D901	H2S8A2TD M7J5-6A
⊕4	D902	H2S8B2TD M7J4-7C

NOTICE
 (J)..... Japanese model
 (U)..... U.S.A model
 (C)..... Canadian model
 (A)..... Australian model
 (E)..... European model
 (G)..... European model
 (B)..... British model
 (R)..... General model
 (P)..... RP model

RESISTOR

REMARKS	PARTS NAME
NO MARK	CARBON FILM RESISTOR (P=5)
□	CARBON FILM RESISTOR (P=10)
△	METAL OXIDE FILM RESISTOR
▲	METAL FILM RESISTOR
⊗	METAL PLATE RESISTOR
⊠	FIRE PROOF CARBON FILM RESISTOR
□	CEMENT MOLDED RESISTOR
⊕	SEMI VARIABLE RESISTOR
■	CHIP RESISTOR

CAPACITOR

REMARKS	PARTS NAME
NO MARK	ELECTROLYTIC CAPACITOR
⊕	TANTALUM CAPACITOR
⊙	CERAMIC CAPACITOR
⊕	CERAMIC TUBULAR CAPACITOR
⊗	POLYESTER FILM CAPACITOR
⊖	POLYSTYRENE FILM CAPACITOR
⊕	MICA CAPACITOR
⊕	POLYPROPYLENE FILM CAPACITOR
●	SEMICONDUCTIVE CERAMIC CAPACITOR

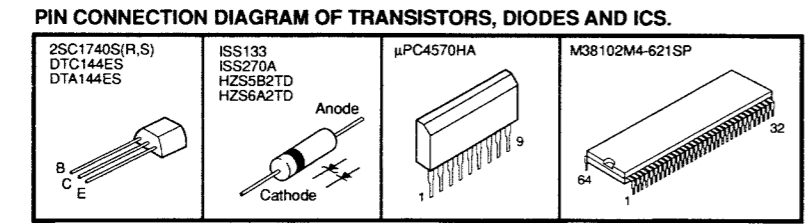

PARTS LIST

ELECTRICAL PARTS

WARNING

Components having special characteristics are marked \triangle and must be replaced with parts having specifications equal to those originally installed.

● Carbon resistors (1/6W or 1/4W) are not included in the ELECTRICAL PARTS List. For the parts No. of the carbon resistors, refer to last page.

ABBREVIATIONS IN THIS LIST ARE AS FOLLOWS :

C.A.EL.CHP	: CHIP ALUMI. ELECTROLYTIC CAP	L.EMIT	: LIGHT EMITTING MODULE
C.CE	: CERAMIC CAP	LED.DSPLY	: LED DISPLAY
C.CE.ARRAY	: CERAMIC CAP ARRAY	LED.INFRD	: LED, INFRARED
C.CE.CHP	: CHIP CERAMIC CAP	MODUL.RF	: MODULATOR, RF
C.CE.ML	: MULTILAYER CERAMIC CAP	PHOT.CPL	: PHOTO COUPLER
C.CE.M.CHP	: CHIP MULTILAYER CERAMIC CAP	PHOT.INTR	: PHOTO INTERRUPTER
C.CE.SAFTY	: RECOGNIZED CERAMIC CAP	PHOT.RFLCT	: PHOTO REFLECTOR
C.CE.TUBLR	: CERAMIC TUBULAR CAP	PIN.TEST	: PIN, TEST POINT
C.CE.SMI	: SEMI CONDUCTIVE CERAMIC CAP	PLST.RIVET	: PLASTIC RIVET
C.EL	: ELECTROLYTIC CAP	R.ARRAY	: RESISTOR ARRAY
C.MICA	: MICA CAP	R.CAR	: CARBON RESISTOR
C.ML.FLM	: MULTILAYER FILM CAP	R.CAR.CHP	: CHIP RESISTOR
C.MP	: METALLIZED PAPER CAP	R.CAR.FP	: FLAME PROOF CARBON RESISTOR
C.MYLAR	: MYLAR FILM CAP	R.FUS	: FUSABLE RESISTOR
C.MYLAR.ML	: MULTILAYER MYLAR FILM CAP	R.MTL.CHP	: CHIP METAL FILM RESISTOR
C.PAPER	: PAPER CAPACITOR	R.MTL.FLM	: METAL FILM RESISTOR
C.PLS	: POLYSTYRENE FILM CAP	R.MTL.OXD	: METAL OXIDE FILM RESISTOR
C.POL	: POLYESTER FILM CAP	R.MTL.PLAT	: METAL PLATE RESISTOR
C.POLY	: POLYETHYLENE FILM CAP	RSNR.CE	: CERAMIC RESONATOR
C.PP	: POLYPROPYLENE FILM CAP	RSNR.CRYS	: CRYSTAL RESONATOR
C.TNTL	: TANTALUM CAP	R.TW.CEM	: TWIN CEMENT FIXED RESISTOR
C.TNTL.CHP	: CHIP TANTALUM CAP	R.WW	: WIRE WOUND RESISTOR
C.TRIM	: TRIMMER CAP	SCR.BND.HD	: BIND HEAD B-TITE SCREW
CN	: CONNECTOR	SCR.BW.HD	: BW HEAD TAPPING SCREW
CN.BS.PIN	: CONNECTOR, BASE PIN	SCR.CUP	: CUP TITE SCREW
CN.CANNON	: CONNECTOR, CANNON	SCR.TERM	: SCREW TERMINAL
CN.DIN	: CONNECTOR, DIN	SCR.TR	: SCREW, TRANSISTOR
CN.FLAT	: CONNECTOR, FLAT CABLE	SUPRT.PCB	: SUPPORT, P.C.B.
CN.POST	: CONNECTOR, BASE POST	SURG.PRTCT	: SURGE PROTECTOR
COIL.MX.AM	: COIL, AM MIX	SW.TACT	: TACT SWITCH
COIL.AT.FM	: COIL, FM ANTENNA	SW.LEAF	: LEAF SWITCH
COIL.DT.FM	: COIL, FM DETECT	SW.LEVER	: LEVER SWITCH
COIL.MX.FM	: COIL, FM MIX	SW.MICRO	: MICRO SWITCH
COIL.OUTPT	: OUTPUT COIL	SW.PUSH	: PUSH SWITCH
DIOD.ARRAY	: DIODE ARRAY	SW.RT.ENC	: ROTARY ENCODER
DIODE.BRG	: DIODE BRIDGE	SW.RT.MTR	: ROTARY SWITCH WITH MOTOR
DIODE.CHP	: CHIP DIODE	SW.RT	: ROTARY SWITCH
DIODE.VAR	: VARACTOR DIODE	SW.SLIDE	: SLIDE SWITCH
DIOD.Z.CHP	: CHIP ZENER DIODE	TERM.SP	: SPEAKER TERMINAL
DIODE.ZENR	: ZENER DIODE	TERM.WRAP	: WRAPPING TERMINAL
DSCR.CE	: CERAMIC DISCRIMINATOR	THRMST.CHP	: CHIP THERMISTOR
FER.BEAD	: FERRITE BEADS	TR.CHP	: CHIP TRANSISTOR
FER.CORE	: FERRITE CORE	TR.DGT	: DIGITAL TRANSISTOR
FET.CHP	: CHIP FET	TR.DGT.CHP	: CHIP DIGITAL TRANSISTOR
FL.DSPLY	: FLUORESCENT DISPLAY	TRANS	: TRANSFORMER
FLTR.CE	: CERAMIC FILTER	TRANS.PULS	: PULSE TRANSFORMER
FLTR.COMB	: COMB FILTER MODULE	TRANS.PWR	: POWER TRANSFORMER ASS'y
FLTR.LC.RF	: LC FILTER ,EMI	TUNER.AM	: TUNER PACK, AM
GND.MTL	: GROUND PLATE	TUNER.FM	: TUNER PACK, FM
GND.TERM	: GROUND TERMINAL	TUNER.PK	: FRONT-END TUNER PACK
HOLDER.FUS	: FUSE HOLDER	VR	: ROTARY POTENTIOMETER
IC.PRTCT	: IC PROTECTOR	VR.MTR	: POTENTIOMETER WITH MOTOR
JUMPER.CN	: JUMPER CONNECTOR	VR.SW	: POTENTIOMETER WITH ROTARY SW
JUMPER.TST	: JUMPER, TEST POINT	VR.SLIDE	: SLIDE POTENTIOMETER
L.DTCT	: LIGHT DETECTING MODULE	VR.TRIM	: TRIMMER POTENTIOMETER

Note) Those parts marked with "#" are not included in the P.C.B. ass'y.

P.C.B. DSP

DSP-A590

Schm Ref.	PART NO.	Description		
*	VS711300	P. C. B.	DSP (JRA)	
*	VS711400	P. C. B.	DSP (BG)	
CB1	Vi878700	CN. BS. PIN	9P	
CB2	VK025100	CN. BS. PIN	7P	
CB3	Vi878500	CN. BS. PIN	7P	
CB4	VK025100	CN. BS. PIN	7P	
* CB5	VR358600	CN. BS. PIN	15P	
CB6	Vi878500	CN. BS. PIN	7P	
CB7	VK025100	CN. BS. PIN	7P	
CB8	VK025300	CN. BS. PIN	9P	
CB9	Vi878300	CN. BS. PIN	5P	
CB10	Vi878500	CN. BS. PIN	7P	
CB11	Vi878700	CN. BS. PIN	9P	
C1	VJ839100	C. EL	1uF	50V
C2	UA652100	C. MYLAR	100pF	50V (BG)
C3	UA652220	C. MYLAR	220pF	50V
C4	UA652100	C. MYLAR	100pF	50V (BG)
C5	UA652220	C. MYLAR	220pF	50V
C6	VJ839100	C. EL	1uF	50V
C7	VK534000	C. PP	220pF	200V
C8	VK534000	C. PP	220pF	200V
C9	VG278400	C. CE. TUBLR	220pF	50V
C10	VG278400	C. CE. TUBLR	220pF	50V
C11	VG278400	C. CE. TUBLR	220pF	50V
C12	VG278400	C. CE. TUBLR	220pF	50V
C13	VG278400	C. CE. TUBLR	220pF	50V
C14	VG278400	C. CE. TUBLR	220pF	50V
C15	UA652220	C. MYLAR	220pF	50V
C16	UA652220	C. MYLAR	220pF	50V
C17	VG278400	C. CE. TUBLR	220pF	50V
C18	VG278400	C. CE. TUBLR	220pF	50V
C19	UA652220	C. MYLAR	220pF	50V
C20	UA652220	C. MYLAR	220pF	50V
C21	VG278400	C. CE. TUBLR	220pF	50V
C22	VG278400	C. CE. TUBLR	220pF	50V
C23	UA652220	C. MYLAR	220pF	50V
C24	UA652220	C. MYLAR	220pF	50V
C25	VJ839200	C. EL	2. 2uF	50V
C26	VE117600	C. EL	220uF	10V
C27	VJ837200	C. EL	47uF	16V
C28	UA653910	C. MYLAR	9100pF	50V
C29	UA654330	C. MYLAR	0. 033uF	50V
C30	UA653910	C. MYLAR	9100pF	50V
C31	UA654330	C. MYLAR	0. 033uF	50V
C32	VJ837200	C. EL	47uF	16V
C33	VE117600	C. EL	220uF	10V
C34	VJ839200	C. EL	2. 2uF	50V
C35	UM417100	C. EL	10uF	50V
C36	UA652100	C. MYLAR	100pF	50V
C37	UM417100	C. EL	10uF	50V
C38	UM417100	C. EL	10uF	50V
C39	UA652100	C. MYLAR	100pF	50V
C40	VH053100	C. CE. TUBLR	0. 1uF	50V

* New Parts

Schm Ref.	PART NO.	Description		
C41	VJ839100	C. EL	1uF	50V
C42	UA652100	C. MYLAR	100pF	50V
C43	UA652100	C. MYLAR	100pF	50V
C44	UA652100	C. MYLAR	100pF	50V
C45	UA652100	C. MYLAR	100pF	50V
C46	VJ839100	C. EL	1uF	50V
C47	UA652100	C. MYLAR	100pF	50V
C48	UA655150	C. MYLAR	0. 15uF	50V
C49	VJ839100	C. EL	1uF	50V
C50	VJ839100	C. EL	1uF	50V
C51	UM417100	C. EL	10uF	50V
C52	VF466800	C. CE. TUBLR	100pF	50V
C53	VG279600	C. CE. TUBLR	3300pF	16V
C54	UM417100	C. EL	10uF	50V
C55	UM417100	C. EL	10uF	50V
C56	UM417100	C. EL	10uF	50V
C57	VG279600	C. CE. TUBLR	3300pF	16V
C58	VF466800	C. CE. TUBLR	100pF	50V
C59	VG279600	C. CE. TUBLR	3300pF	16V
C60	VJ837200	C. EL	47uF	16V
C61	VJ837200	C. EL	47uF	16V
C62	UM417100	C. EL	10uF	50V
C63	VG278400	C. CE. TUBLR	220pF	50V
C64	VG278400	C. CE. TUBLR	220pF	50V
C65	UM417100	C. EL	10uF	50V
C66	VF964800	C. EL	100uF	16V
C67	VG279600	C. CE. TUBLR	3300pF	16V
C68	UA253330	C. MYLAR	3300pF	50V
C69	UA253120	C. MYLAR	1200pF	50V
C70	UA253100	C. MYLAR	1000pF	50V
C71	FG212150	C. CE	150pF	50V
C72	FG212150	C. CE	150pF	50V
C73	FG212150	C. CE	150pF	50V
C74	FG212150	C. CE	150pF	50V
C75	UA253120	C. MYLAR	1200pF	50V
C76	UA253100	C. MYLAR	1000pF	50V
C77	UA253330	C. MYLAR	3300pF	50V
C78	UM407220	C. EL	22uF	25V
C79	UM407220	C. EL	22uF	25V
C80	UM407220	C. EL	22uF	25V
C81	UM407220	C. EL	22uF	25V
C82	UA652330	C. MYLAR	330pF	50V
C83	UM407220	C. EL	22uF	25V
C84	UM407220	C. EL	22uF	25V
C85	UA652330	C. MYLAR	330pF	50V
C86	UA652330	C. MYLAR	330pF	50V
C87	UM407220	C. EL	22uF	25V
C88	UM407220	C. EL	22uF	25V
C89	VJ839100	C. EL	1uF	50V
C90	VG277000	C. CE. TUBLR	33pF	50V
C91	VG278400	C. CE. TUBLR	220pF	50V
C92	VG279500	C. CE. TUBLR	2700pF	16V
C93	VG278400	C. CE. TUBLR	220pF	50V

* New Parts

P.C.B. DSP

Schm Ref.	PART NO.	Description		
C94	VG279500	C. CE. TUBLR	2700pF	16V
C95	VG277000	C. CE. TUBLR	33pF	50V
C96	VJ839100	C. EL	1uF	50V
C97	VG277000	C. CE. TUBLR	33pF	50V
C98	VG279500	C. CE. TUBLR	2700pF	16V
C99	VF466600	C. CE. TUBLR	10pF	50V
C100	VF466600	C. CE. TUBLR	10pF	50V
C101	VG279500	C. CE. TUBLR	2700pF	16V
C102	VG277000	C. CE. TUBLR	33pF	50V
C103	VH053100	C. CE. TUBLR	0. 1uF	50V
C104	VG278400	C. CE. TUBLR	220pF	50V
C105	VH053100	C. CE. TUBLR	0. 1uF	50V
C106	VG278400	C. CE. TUBLR	220pF	50V
C107	UA653270	C. MYLAR	2700pF	50V
C108	UM407220	C. EL	22uF	25V
C109	UM407220	C. EL	22uF	25V
C110	UA653270	C. MYLAR	2700pF	50V
C111	VG279600	C. CE. TUBLR	3300pF	16V
C112	VG279600	C. CE. TUBLR	3300pF	16V
C113	VH053100	C. CE. TUBLR	0. 1uF	50V
C114	VH053100	C. CE. TUBLR	0. 1uF	50V
C115	UJ638330	C. EL	330uF	16V
C116	VH053100	C. CE. TUBLR	0. 1uF	50V
C117	VH053100	C. CE. TUBLR	0. 1uF	50V
C118	VJ837200	C. EL	47uF	16V
C119	VJ837200	C. EL	47uF	16V
C120	VJ837200	C. EL	47uF	16V
C121	VJ837200	C. EL	47uF	16V
C122	VE117600	C. EL	220uF	10V
C123	VJ837200	C. EL	47uF	16V
C124	VH053100	C. CE. TUBLR	0. 1uF	50V
C125	VJ837200	C. EL	47uF	16V
C126	VH053100	C. CE. TUBLR	0. 1uF	50V
C127	VJ839000	C. EL	0. 47uF	50V
C128	VJ839000	C. EL	0. 47uF	50V
C129	VJ839200	C. EL	2. 2uF	50V
C130	VJ839200	C. EL	2. 2uF	50V
C131	VJ839200	C. EL	2. 2uF	50V
C134	UA652100	C. MYLAR	100pF	50V
C135	UA652100	C. MYLAR	100pF	50V
C136	UM417100	C. EL	10uF	50V
C137	UM215100	C. EL	0. 1uF	50V
C138	UM417100	C. EL	10uF	50V
C139	FG211100	C. CE	10pF	50V
C140	VJ837200	C. EL	47uF	16V
C141	UM215100	C. EL	0. 1uF	50V
C142	FG212100	C. CE	100pF	50V
C143	UM417100	C. EL	10uF	50V
C144	UM417100	C. EL	10uF	50V
C145	VJ837200	C. EL	47uF	16V
C146	UM215100	C. EL	0. 1uF	50V
C147	UM417100	C. EL	10uF	50V
C148	FG211100	C. CE	10pF	50V

* New Parts

Schm Ref.	PART NO.	Description		
C148	FG211100	C. CE	10pF	50V (JRA)
C148	FG212100	C. CE	100pF	50V (BG)
C149	VJ837200	C. EL	47uF	16V
C150	VJ837200	C. EL	47uF	16V
C151	UM215100	C. EL	0. 1uF	50V
C152	FG211100	C. CE	10pF	50V
C152	FG212100	C. CE	100pF	50V (JRA)
C152	FG212100	C. CE	100pF	50V (BG)
C153	VJ837200	C. EL	47uF	16V
C154	UM417100	C. EL	10uF	50V
C155	VF466800	C. CE. TUBLR	100pF	50V
C156	VF466800	C. CE. TUBLR	100pF	50V
C157	VJ836900	C. EL	10uF	16V
C158	VJ836900	C. EL	10uF	16V
C159	VJ836900	C. EL	10uF	16V
C160	VF637900	C. EL	1000uF	10V
C161	VF466800	C. CE. TUBLR	100pF	50V
C162	VF637900	C. EL	1000uF	10V
C163	VF466800	C. CE. TUBLR	100pF	50V
C164	VF637900	C. EL	1000uF	10V
C165	VF466800	C. CE. TUBLR	100pF	50V
C166	UM417100	C. EL	10uF	50V
C167	VJ839100	C. EL	1uF	50V
* C168	VG722100	C. EL	1uF	50V
C169	VH053100	C. CE. TUBLR	0. 1uF	50V
C170	UM417100	C. EL	10uF	50V
C171	VJ836900	C. EL	10uF	16V
C172	VJ837200	C. EL	47uF	16V
C173	VF637900	C. EL	1000uF	10V
C174	VG276600	C. CE. TUBLR	22pF	50V
C175	VJ837200	C. EL	47uF	16V
C176	VF637900	C. EL	1000uF	10V
C177	VF466800	C. CE. TUBLR	100pF	50V
C178	VF466800	C. CE. TUBLR	100pF	50V
C179	VJ836900	C. EL	10uF	16V
C180	VJ837200	C. EL	47uF	16V
C181	UM397330	C. EL	33uF	16V
C182	VG276600	C. CE. TUBLR	22pF	50V
C183	VJ837200	C. EL	47uF	16V
C184	UM397330	C. EL	33uF	16V
C185	VH053100	C. CE. TUBLR	0. 1uF	50V
C186	VJ837200	C. EL	47uF	16V
C187	UJ638330	C. EL	330uF	16V
C189	UJ638470	C. EL	470uF	16V
C190	VH053100	C. CE. TUBLR	0. 1uF	50V
C191	VJ837200	C. EL	47uF	16V
C192	VH053100	C. CE. TUBLR	0. 1uF	50V
D1	VM975000	DIODE. ZENR	HZS9B2TD	9. 0V
D2	VM975000	DIODE. ZENR	HZS9B2TD	9. 0V
D4	VD631600	DIODE	1SS133, 176, HSS104	
D5	VD631600	DIODE	1SS133, 176, HSS104	
D6	VD631600	DIODE	1SS133, 176, HSS104	
D7	VD631600	DIODE	1SS133, 176, HSS104	

* New Parts

DSP-A590

P.C.B. DSP & MAIN

DSP-A590

Schm Ref.	PART NO.	Description
D8	VD631600	DIODE 1SS133, 176, HSS104
D9	VD631600	DIODE 1SS133, 176, HSS104
D10	VD631600	DIODE 1SS133, 176, HSS104
D11	VD631600	DIODE 1SS133, 176, HSS104
D12	VD631600	DIODE 1SS133, 176, HSS104
D13	VM974200	DIODE. ZENR HZS5C2TD 5.0V
D14	VM974200	DIODE. ZENR HZS5C2TD 5.0V
D15	VD631600	DIODE 1SS133, 176, HSS104
D16	VD631600	DIODE 1SS133, 176, HSS104
IC1	XB247301	IC uPC4570HA
* IC2	XP894A00	IC LC78211
IC3	XB247301	IC uPC4570HA
IC4	XB247301	IC uPC4570HA
IC5	XB247301	IC uPC4570HA
IC6	iG055100	IC TC4053BP
IC7	XB247301	IC uPC4570HA
IC8	XB247301	IC uPC4570HA
IC9	XB247301	IC uPC4570HA
IC10	XB247301	IC uPC4570HA
IC11	XB247301	IC uPC4570HA
IC12	XB247301	IC uPC4570HA
IC13	XQ212A00	IC NJM4558LD
IC14	XB247301	IC uPC4570HA
IC15	XQ212A00	IC NJM4558LD
* IC16	XP896A00	IC LC78213
IC17	Xi022B00	IC YSS203B-F
IC18	XK358A00	IC HM65256BLSP-10
IC19	XA507A00	IC AN78N05
IC20	Xi358A00	IC NJM2904L
* IC21	XP265A00	IC BU2090
IC22	XB247301	IC uPC4570HA
IC23	XB247301	IC uPC4570HA
IC24	XB247301	IC uPC4570HA
IC25	XB247301	IC uPC4570HA
IC26	XE536001	IC LC7535
IC27	XE536001	IC LC7535
IC28	XF494A00	IC LB1641
IC29	XH436A00	IC LA7956
IC30	iG055100	IC TC4053BP
IC31	XH436A00	IC LA7956
IC32	XH436A00	IC LA7956
JK1	VS867300	CN 4P YKF51-5501
JK2	VN938100	CN. DIN 3P S
PJ1	VK421600	JACK. PIN 4P
PJ2	VJ794600	JACK. PIN 6P
PJ3	VJ794600	JACK. PIN 6P
PJ4	VT029100	JACK. PIN 4P
* PJ5	VS549000	JACK. PIN 3P
PJ6	VJ695900	JACK. PIN 3P
PJ7	VJ695900	JACK. PIN 3P
Q1	iC260320	TR 2SC2603 E, F
Q2	iC260320	TR 2SC2603 E, F
Q3	iA101521	TR 2SA1015 Y

* New Parts

Schm Ref.	PART NO.	Description
Q4	iC1815C0	TR 2SC1815 Y
Q5	iA101521	TR 2SA1015 Y
Q6	iC1815C0	TR 2SC1815 Y
Q7	iC260320	TR 2SC2603 E, F
Q8	iC260320	TR 2SC2603 E, F
R35	HV453220	R. CAR. FP 2.2Ω 1/4W
R50	HV453220	R. CAR. FP 2.2Ω 1/4W
R136	HV453220	R. CAR. FP 2.2Ω 1/4W
R137	HV453220	R. CAR. FP 2.2Ω 1/4W
R149	HV453220	R. CAR. FP 2.2Ω 1/4W
R150	HV453220	R. CAR. FP 2.2Ω 1/4W
R151	HL314470	R. MTL. OXD 47Ω 1W
R152	HV453220	R. CAR. FP 2.2Ω 1/4W
R217	HV453470	R. CAR. FP 4.7Ω 1/4W
R218	HV453470	R. CAR. FP 4.7Ω 1/4W
R219	HV454100	R. CAR. FP 10Ω 1/4W
R221	HV454100	R. CAR. FP 10Ω 1/4W
R242	HV453220	R. CAR. FP 2.2Ω 1/4W
VR1	VS868300	VR. MTR A100KΩ
XL1	VK175200	RSNR. CE 11.28MHz
	VB966900	CN IMSA-6024
	VJ828000	PIN IMSA-6024-03E
	BB071360	SCR. TERM 8.3x13
*	VS709600	P. C. B. MAIN (R)
*	VS709700	P. C. B. MAIN (A)
*	VS710000	P. C. B. MAIN (G)
*	VT208900	P. C. B. MAIN (B)
CB501	VK025200	CN 8P
* CB502	VK027100	CN 12P
CB503	VK026300	CN 4P
CB504	VK024900	CN 5P
CB505	VK024700	CN 3P
CB506	VP206500	HOLDER. FUS EYF-52BC
CB507	VP206500	HOLDER. FUS EYF-52BC
CB508	VP206500	HOLDER. FUS EYF-52BC
CB509	VP206500	HOLDER. FUS EYF-52BC
CB510	VK025600	CN 12P
CB511	VP206500	HOLDER. FUS EYF-52BC (R)
CB512	VP206500	HOLDER. FUS EYF-52BC (R)
CB513	VP206500	HOLDER. FUS EYF-52BC
CB514	VP206500	HOLDER. FUS EYF-52BC (G)
CB515	VP206500	HOLDER. FUS EYF-52BC (G)
CB516	VG879900	CN. BS. PIN 2P
* CB517	VL766100	CN. JUMPER 4P
CB518	VK024800	CN 4P
CB519	VP206500	HOLDER. FUS EYF-52BC
CB520	Vi878200	CN. BS. PIN 4P
* CB521	VQ584700	CN. BS. PIN 5P
* CB522	VQ584700	CN. BS. PIN 5P
* CB523	VQ584800	CN. BS. PIN 6P

* New Parts

P.C.B. MAIN

Schm Ref.	PART NO.	Description		
* CB524	VQ584800	CN. BS. PIN	6P	
CB525	Vi879000	CN. BS. PIN	12P	
CB526	Vi878100	CN. BS. PIN	3P	
CB527	Vi878200	CN. BS. PIN	4P	
CB528	Vi878200	CN. BS. PIN	4P	
CB529	LA002110	TERM. WRAP	2P	
CB530	LA002110	TERM. WRAP	2P	
CB531	LA002110	TERM. WRAP	2P	
C501	UM416470	C. EL	4.7uF	50V
C502	VJ839100	C. EL	1uF	50V (AGB)
C503	UM417100	C. EL	10uF	50V
C504	UM417100	C. EL	10uF	50V
C506	VK399200	C. MYLAR. ML	0.39uF	50V
C507	UM416470	C. EL	4.7uF	50V
C508	FG251330	C. CE	33pF	50V
C509	UA652100	C. MYLAR	100pF	50V
C510	FG251330	C. CE	33pF	50V
C511	UA652100	C. MYLAR	100pF	50V
C512	FG251330	C. CE	33pF	50V
C513	UM417100	C. EL	10uF	50V
C514	UA652100	C. MYLAR	100pF	50V
C516	VK399200	C. MYLAR. ML	0.39uF	50V
C517	VQ245400	C. PP	33pF	200V (GB)
* C517	VS696700	C. CE	33pF	500V (RA)
C518	VJ837200	C. EL	47uF	16V
C519	UA253100	C. MYLAR	1000pF	50V
C520	VQ245400	C. PP	33pF	200V (GB)
* C520	VS696700	C. CE	33pF	500V (RA)
C521	VJ837200	C. EL	47uF	16V
C522	UA253100	C. MYLAR	1000pF	50V
C523	VQ245400	C. PP	33pF	200V (GB)
* C523	VS696700	C. CE	33pF	500V (RA)
C524	VJ837200	C. EL	47uF	16V
C525	UA253100	C. MYLAR	1000pF	50V
* C526	VR325000	C. MYLAR	100pF	100V
C527	UJ667470	C. EL	47uF	50V
C528	UJ667470	C. EL	47uF	50V
* C529	VR325000	C. MYLAR	100pF	100V
C530	VK699400	C. EL	330uF	63V
* C531	VR325000	C. MYLAR	100pF	100V
C532	UJ667470	C. EL	47uF	50V
C533	UJ667470	C. EL	47uF	50V
* C534	VR325000	C. MYLAR	100pF	100V
* C535	VR325000	C. MYLAR	100pF	100V
C536	UJ667470	C. EL	47uF	50V
C537	UJ667470	C. EL	47uF	50V
* C538	VR325000	C. MYLAR	100pF	100V
C539	VJ836900	C. EL	10uF	16V
C540	VJ839200	C. EL	2.2uF	50V
C541	VJ839100	C. EL	1uF	50V
C542	UA654680	C. MYLAR	0.068uF	50V
C543	UA654680	C. MYLAR	0.068uF	50V
C544	UA654680	C. MYLAR	0.068uF	50V

* New Parts

Schm Ref.	PART NO.	Description		
C545	UA654100	C. MYLAR	0.01uF	50V (GB)
C546	UA654220	C. MYLAR	0.022uF	50V (GB)
C547	UA654220	C. MYLAR	0.022uF	50V (GB)
C548	UA654220	C. MYLAR	0.022uF	50V (GB)
C549	UA654220	C. MYLAR	0.022uF	50V (GB)
C550	UA654100	C. MYLAR	0.01uF	50V (GB)
C551	UA654100	C. MYLAR	0.01uF	50V (GB)
* C552	VS529200	C. EL	10000uF	63V (GB)
* C552	VS578300	C. EL	10000uF	63V (RA)
* C553	VS529200	C. EL	10000uF	63V (GB)
* C553	VS578300	C. EL	10000uF	63V (RA)
C554	UA654100	C. MYLAR	0.01uF	50V (GB)
C555	UA654100	C. MYLAR	0.01uF	50V (GB)
* C556	VS745400	C. POL. MT	0.1uF	100V
* C557	VS745400	C. POL. MT	0.1uF	100V
C558	VJ837200	C. EL	47uF	16V
C559	FG210500	C. CE	5pF	50V (GB)
C559	FG251220	C. CE	22pF	50V (RA)
C560	UA253100	C. MYLAR	1000pF	50V (GB)
C560	UA652470	C. MYLAR	470pF	50V (RA)
C561	VJ837200	C. EL	47uF	16V
C562	UM417100	C. EL	10uF	50V
C563	UM417100	C. EL	10uF	50V
C564	VJ839000	C. EL	0.47uF	50V
C565	VJ839000	C. EL	0.47uF	50V
C566	UM417100	C. EL	10uF	50V
C567	VJ837200	C. EL	47uF	16V
C568	FG210500	C. CE	5pF	50V (GB)
C568	FG251220	C. CE	22pF	50V (RA)
C569	UA253100	C. MYLAR	1000pF	50V (GB)
C569	UA652470	C. MYLAR	470pF	50V (RA)
C570	VJ837200	C. EL	47uF	16V
C571	UJ648470	C. EL	470uF	25V
* C572	VR325000	C. MYLAR	100pF	100V
C573	UA654100	C. MYLAR	0.01uF	50V
C574	VF466800	C. CE. TUBLR	100pF	50V
* C575	VR325000	C. MYLAR	100pF	100V
* C576	VR325000	C. MYLAR	100pF	100V
C577	UA654100	C. MYLAR	0.01uF	50V
C578	UM417100	C. EL	10uF	50V
C579	VF466800	C. CE. TUBLR	100pF	50V
* C580	VR325000	C. MYLAR	100pF	100V
C581	Ui377470	C. EL	47uF	63V (R)
C582	FG213100	C. CE	1000pF	50V (R)
C583	UA655100	C. MYLAR	0.1uF	50V (GB)
C584	UA654470	C. MYLAR	0.047uF	50V
C585	FG214100	C. CE	0.01uF	50V
C586	UA654100	C. MYLAR	0.01uF	50V
C587	VL544800	C. EL	3300uF	35V
C588	VG289900	C. EL	2200uF	35V
C589	UM416470	C. EL	4.7uF	50V
C590	VS741700	C. CE. SAFTY	0.01uF	275V
* C591	VS745400	C. POL. MT	0.1uF	100V

* New Parts

DSP-A590

P.C.B. MAIN

DSP-A590

Schm Ref.	PART NO.	Description		
* C592	VS745400	C. POL. MT	0.1uF	100V
C593	UJ667470	C. EL	47uF	50V
C594	VJ839000	C. EL	0.47uF	50V
C595	VJ837200	C. EL	47uF	16V
C596	VF466900	C. CE. TUBLR	470pF	50V
C597	VF466900	C. CE. TUBLR	470pF	50V
C598	VF466900	C. CE. TUBLR	470pF	50V
C599	VF466900	C. CE. TUBLR	470pF	50V
C600	VF466900	C. CE. TUBLR	470pF	50V
C601	UA654470	C. MYLAR	0.047uF	50V
C602	VJ839000	C. EL	0.47uF	50V
C603	UA654100	C. MYLAR	0.01uF	50V (GB)
C604	UA654220	C. MYLAR	0.022uF	50V (GB)
C605	UA654100	C. MYLAR	0.01uF	50V (GB)
C606	UA654100	C. MYLAR	0.01uF	50V (GB)
C607	UA654220	C. MYLAR	0.022uF	50V (GB)
C610	VH053100	C. CE. TUBLR	0.1uF	50V (GB)
C615	VF466800	C. CE. TUBLR	100pF	50V (GB)
C616	VF466800	C. CE. TUBLR	100pF	50V (GB)
C620	FG244220	C. CE	0.022uF	50V (GB)
D501	VM976300	DIODE. ZENR	HZS242TD	24V
D502	VM976300	DIODE. ZENR	HZS242TD	24V
D503	VM974500	DIODE. ZENR	HZS6C2TD	6.0V
D504	VD631600	DIODE	1SS133, 176, HSS104	
D505	VM974400	DIODE. ZENR	HZS6B2TD	6.0V
D506	VNO08700	DIODE	1SS270A	
D507	VNO08700	DIODE	1SS270A	
D508	VNO08700	DIODE	1SS270A	
△ D510	VNO11400	DIODE. BRG	D5SB20	5A 200V
D511	VM975800	DIODE. ZENR	HZS152TD	15V
D512	VM976300	DIODE. ZENR	HZS242TD	24V
D513	VD631600	DIODE	1SS133, 176, HSS104	
D514	VM976300	DIODE. ZENR	HZS242TD	24V
D515	VM975800	DIODE. ZENR	HZS152TD	15V
D516	VD631600	DIODE	1SS133, 176, HSS104	
D517	VD631600	DIODE	1SS133, 176, HSS104	
D518	VD631600	DIODE	1SS133, 176, HSS104	
D519	VD631600	DIODE	1SS133, 176, HSS104	
D520	VM975600	DIODE. ZENR	HZS12B2TD	12V (R)
△ D521	VR253700	DIODE. BRG	S1NB20	1.0A 200V
D522	VM976300	DIODE. ZENR	HZS242TD	24V
△ D523	VNO11300	DIODE. BRG	D3SBA20	4A 200V
D524	VM975700	DIODE. ZENR	HZS12C2TD	12V
△ F501	KB000790	FUSE	T4. 0A	250V (RGB)
△ F501	VS822900	FUSE	T4. 0A	125V (R)
△ F502	KB000790	FUSE	T4. 0A	250V (AGB)
△ F502	VS822900	FUSE	T4. 0A	125V (R)
△ F503	KB002980	FUSE	T2. 5A	250V (G)
△ F504	KB000760	FUSE	T3. 15A	250V (R)
△ F505	KB000760	FUSE	T3. 15A	250V (AGB)
△ F505	VP909900	FUSE	T7. 0A	125V (R)
IC501	iG092000	IC	M5220L	
IC502	XD343A00	IC	NJM79M12FA	

* New Parts

Schm Ref.	PART NO.	Description		
JK501	LB301720	JACK. PHONE		
△ JK502	VK480600	CN. OUTLET	(R)	
△ JK502	VK480700	CN. OUTLET	(G)	
* L501	VR906600	COIL	0.95uH	
* L502	VR906600	COIL	0.95uH	
* L503	VP575600	COIL	1.5uH	
* L504	VP575600	COIL	1.5uH	
* L505	VP575600	COIL	1.5uH	
PJ501	VR245000	JACK. PIN	6P	
Q501	VK432900	TR	2SD1915F S, T	(AGB)
Q502	VK432900	TR	2SD1915F S, T	
Q503	VK432900	TR	2SD1915F S, T	(AGB)
Q504	VK432900	TR	2SD1915F S, T	
Q505	VK432900	TR	2SD1915F S, T	
Q506	iA101521	TR	2SA1015	Y
* Q507	VP883000	TR	2SA893A	D, E
* Q508	VP883000	TR	2SA893A	D, E
* Q509	VP883000	TR	2SA893A	D, E
Q510	iC224030	TR	2SC2240	GR, BL
* Q511	VP883000	TR	2SA893A	D, E
* Q512	VP883000	TR	2SA893A	D, E
* Q513	VP883000	TR	2SA893A	D, E
Q514	VC218900	TR	2SC3330	R, S, T
* Q515	VR325600	TR	2SC2229	O, Y
Q516	VC218900	TR	2SC3330	R, S, T
* Q517	VR325600	TR	2SC2229	O, Y
Q518	VC218900	TR	2SC3330	R, S, T
* Q519	VR325600	TR	2SC2229	O, Y
Q520	iD040040	TR	2SD400	
Q521	iA093320	TR	2SA933S	Q, R
Q522	iX603580	TR	2SA1358	
# Q523A	iX606460	TR	2SA1492	O, P, Y
# Q523C	iX606470	TR	2SC3856	O, P, Y
Q526	iX603580	TR	2SA1358	
# Q527A	iX606460	TR	2SA1492	O, P, Y
# Q527C	iX606470	TR	2SC3856	O, P, Y
Q530	iX603580	TR	2SA1358	
# Q531A	iX633340	TR	2SA1695	O, P, Y
# Q531C	iX633350	TR	2SC4468	O, P, Y
Q534	iA097000	TR	2SA970	GR, BL
* Q535	VP883100	TR	2SC1890A	D, E
* Q536	VP883100	TR	2SC1890A	D, E
* Q537	VP883100	TR	2SC1890A	D, E
Q538	VK432900	TR	2SD1915F	S, T
Q539	VK432900	TR	2SD1915F	S, T
Q540	iC1815C0	TR	2SC1815	Y
Q541	iA101521	TR	2SA1015	Y
Q542	VC218900	TR	2SC3330	R, S, T
Q543	iX619590	TR	2SA1726	O, P, Y
* Q544	VP872700	TR	2SC4488	S, T
* Q545	VP872600	TR	2SA1708	S, T
Q546	iC224030	TR	2SC2240	GR, BL
Q548	iX619590	TR	2SA1726	O, P, Y

* New Parts

P.C.B. MAIN & OPERATION

P.C.B. OPERATION

Schm Ref.	PART NO.	Description
* Q549	VP872700	TR 2SC4488 S, T
* Q550	VP872600	TR 2SA1708 S, T
Q551	iC224030	TR 2SC2240 GR, BL
Q553	VR510800	TR 2SD2396 J, K(R)
Q555	iC224030	TR 2SC2240 GR, BL
Q556	iC224030	TR 2SC2240 GR, BL
Q557	VN996900	TR 2SC4495
Q558	iE000020	FET 2SK30ATM GR
Q559	VK432900	TR 2SD1915F S, T
Q560	VK432900	TR 2SD1915F S, T
Q561	VK432900	TR 2SD1915F S, T
R517	HV456100	R. CAR. FP 1KΩ 1/4W
R531	HV455150	R. CAR. FP 150Ω 1/4W
* R553	HL316560	R. MTL. OXD 5.6KΩ 1W
* R554	HL316560	R. MTL. OXD 5.6KΩ 1W
R555	HV456270	R. CAR. FP 2.7KΩ 1/4W
R557	HV455820	R. CAR. FP 820Ω 1/4W
R558	VK189000	R. FUS 1KΩ 1/4W
R559	HV454470	R. CAR. FP 47Ω 1/4W
R560	HL314100	R. MTL. OXD 10Ω 1W
* R561	HL316560	R. MTL. OXD 5.6KΩ 1W
* R562	HL316560	R. MTL. OXD 5.6KΩ 1W
R563	HV456270	R. CAR. FP 2.7KΩ 1/4W
R565	HV455820	R. CAR. FP 820Ω 1/4W
R566	VK189000	R. FUS 1KΩ 1/4W
R567	HV454470	R. CAR. FP 47Ω 1/4W
* R568	HL316560	R. MTL. OXD 5.6KΩ 1W
* R569	HL316560	R. MTL. OXD 5.6KΩ 1W
R570	HV456270	R. CAR. FP 2.7KΩ 1/4W
R572	HV455820	R. CAR. FP 820Ω 1/4W
R573	VK189000	R. FUS 1KΩ 1/4W
R574	HV454470	R. CAR. FP 47Ω 1/4W
R580	HV453470	R. CAR. FP 4.7Ω 1/4W
R581	VK188400	R. FUS 330Ω 1/4W
R582	VJ695400	R. WW 0.22Ωx2 3W
R583	HV453470	R. CAR. FP 4.7Ω 1/4W
R584	HV453470	R. CAR. FP 4.7Ω 1/4W
R585	VK188400	R. FUS 330Ω 1/4W
R586	VJ695400	R. WW 0.22Ωx2 3W
R587	HV453470	R. CAR. FP 4.7Ω 1/4W
R588	HV453470	R. CAR. FP 4.7Ω 1/4W
R589	VK188400	R. FUS 330Ω 1/4W
* R590	HZ003780	R. MTL. PLAT 0.22Ω+0.22 5W
R591	HV453470	R. CAR. FP 4.7Ω 1/4W
R598	HL314100	R. MTL. OXD 10Ω 1W
R603	HL314100	R. MTL. OXD 10Ω 1W
R609	HL314100	R. MTL. OXD 10Ω 1W
R611	HV454100	R. CAR. FP 10Ω 1/4W
R613	HV454100	R. CAR. FP 10Ω 1/4W
R614	VP944500	R. MTL. OXD 390Ω 1W
R615	VP944500	R. MTL. OXD 390Ω 1W
R633	HV455390	R. CAR. FP 390Ω 1/4W
R640	HV455390	R. CAR. FP 390Ω 1/4W

* New Parts

Schm Ref.	PART NO.	Description
R643	HV455330	R. CAR. FP 330Ω 1/4W
R644	VE869300	R. MTL. OXD 0.1Ω 2W
R648	HV454220	R. CAR. FP 22Ω 1/4W
R649	HV454470	R. CAR. FP 47Ω 1/4W
R650	HV455330	R. CAR. FP 330Ω 1/4W
R652	VE869300	R. MTL. OXD 0.1Ω 2W
R655	HV454220	R. CAR. FP 22Ω 1/4W
R656	HV454470	R. CAR. FP 47Ω 1/4W
R657	HV456560	R. CAR. FP 5.6KΩ 1/4W(R)
R658	HV456560	R. CAR. FP 5.6KΩ 1/4W(R)
R661	HV456150	R. CAR. FP 1.5KΩ 1/4W
R662	HV456220	R. CAR. FP 2.2KΩ 1/4W
R666	HV456150	R. CAR. FP 1.5KΩ 1/4W
R667	HV456220	R. CAR. FP 2.2KΩ 1/4W
R668	HV453220	R. CAR. FP 2.2Ω 1/4W
R670	HV454100	R. CAR. FP 10Ω 1/4W
R671	HL313220	R. MTL. FLM 2.2Ω 1W
R672	HV455150	R. CAR. FP 150Ω 1/4W
R673	HL313220	R. MTL. FLM 2.2Ω 1W
R674	HV453220	R. CAR. FP 2.2Ω 1/4W
R687	HV454100	R. CAR. FP 10Ω 1/4W
R688	HV453220	R. CAR. FP 2.2Ω 1/4W
R689	HV454100	R. CAR. FP 10Ω 1/4W
R690	HL325470	R. MTL. OXD 470Ω 2W
R700	HL325470	R. MTL. OXD 470Ω 2W
RY501	VK438300	RELAY DH24D2-OTM-
RY502	VS533600	RELAY DC DH24D2-OS(M) II
RY503	VH230800	RELAY G5P-1-DC12V
SW501	VJ850200	SW. PUSH PSE021A2KP 2
* SW502	VS602600	SW. SLIDE SS070-PO22 A(AGB)
△ SW511	VA961800	VOLT. SELCT ESE-37247-F(R)
△ T501	XC082A00	TRANS. PWR (R)
△ T501	XC084A00	TRANS. PWR (AGB)
TE501	VC313700	TERM. SP 8P(R)
TE501	VK506200	TERM. SP 8P(AGB)
* TE502	VS578600	TERM. SP 8P
	VJ828000	PIN IMSA-6024-03E
	VS605900	HEAT. SINK DPS15-45(R)
	VS606000	HEAT. SINK DPS35-45
	BB071360	SCR. TERM 8.3x13
	VR264300	GND. MTL
	EP630280	SCR. BND. HD 3x10 FCRM3-BL
	LA000280	TERM. LUG 1P(GB)
	VS710900	P. C. B. OPERATION(JRA)
	VS711000	P. C. B. OPERATION(BG)
* CB901	VR362200	CN. BS. PIN 15P
* CB902	Vi879000	CN. BS. PIN 12P
* CB903	Vi878700	CN. BS. PIN 9P
* CB904	Vi878600	CN. BS. PIN 8P
C901	VJ839200	C. EL 2.2uF 50V

* New Parts

Schm Ref.	PART NO.	Description
C902	VJ837200	C. EL 47uF 16V
C903	UA652100	C. MYLAR 100pF 50V
C904	VJ839200	C. EL 2.2uF 50V
C905	VJ839200	C. EL 2.2uF 50V
C906	UA652100	C. MYLAR 100pF 50V
C907	VJ837200	C. EL 47uF 16V
C908	VR357400	C. EL 4700uF 5.5V
C909	VH053100	C. CE. TUBLR 0.1uF 50V
C910	VF637900	C. EL 1000uF 10V
C911	UM407220	C. EL 22uF 25V
C912	UA655120	C. MYLAR 0.12uF 50V
C913	UA655120	C. MYLAR 0.12uF 50V
C914	UM407220	C. EL 22uF 25V
C915	VJ839000	C. EL 0.47uF 50V
C916	VH053100	C. CE. TUBLR 0.1uF 50V
C917	UA654330	C. MYLAR 0.033uF 50V
C918	VJ839000	C. EL 0.47uF 50V
C919	VJ839000	C. EL 0.47uF 50V
C920	UA654330	C. MYLAR 0.033uF 50V
C921	UM407220	C. EL 22uF 25V
C922	UM407220	C. EL 22uF 25V
C923	VH053100	C. CE. TUBLR 0.1uF 50V
C924	VJ837200	C. EL 47uF 16V
D901	VM974300	DIODE. ZENR HZS6A2TD 6.0V
D902	VM974100	DIODE. ZENR HZS5B2TD 5.0V
D903	VD631600	DIODE 1SS133, 176, HSS104
D904	VD631600	DIODE 1SS133, 176, HSS104
D905	VD631600	DIODE 1SS133, 176, HSS104
D906	VP594000	LED(re) SLR-305VCA47 (BG)
D907	VNO08700	DIODE 1SS270A
D908	VNO08700	DIODE 1SS270A
D909	VNO08700	DIODE 1SS270A
D914	VNO08700	DIODE 1SS270A
D915	VNO08700	DIODE 1SS270A
D916	VNO08700	DIODE 1SS270A
D918	VD631600	DIODE 1SS133, 176, HSS104
G901	VR463400	TERM. GND D3.5 TP00385
IC901	XB247301	IC uPC4570HA
IC902	XB247301	IC uPC4570HA
IC903	XQ087A00	IC M38102M4-621SP
Q901	VD678500	TR. DGT DTA114ES
Q902	iC174020	TR 2SC1740S R, S
Q903	VG722000	TR. DGT DTC144ES
R936	HV455100	R. CAR. FP 100Ω 1/4W
R939	HV455100	R. CAR. FP 100Ω 1/4W
SW901	VG392900	SW. TACT SKHVAA
SW902	VG392900	SW. TACT SKHVAA
SW903	VG392900	SW. TACT SKHVAA
SW904	VG392900	SW. TACT SKHVAA
SW905	VG392900	SW. TACT SKHVAA
SW906	VG392900	SW. TACT SKHVAA
SW907	VG392900	SW. TACT SKHVAA
SW908	VG392900	SW. TACT SKHVAA

* New Parts

Schm Ref.	PART NO.	Description
SW909	VG392900	SW. TACT SKHVAA
SW912	VG392900	SW. TACT SKHVAA
SW915	VG392900	SW. TACT SKHVAA
SW918	VG392900	SW. TACT SKHVAA
SW921	VG392900	SW. TACT SKHVAA
SW922	VG392900	SW. TACT SKHVAA
SW924	VG392900	SW. TACT SKHVAA
SW927	VG392900	SW. TACT SKHVAA
SW930	VG392900	SW. TACT SKHVAA
SW933	VG392900	SW. TACT SKHVAA
SW934	VG392900	SW. TACT SKHVAA
SW935	VG392900	SW. TACT SKHVAA
SW936	VG392900	SW. TACT SKHVAA
SW937	VG392900	SW. TACT SKHVAA
SW938	VG392900	SW. TACT SKHVAA
SW939	VG392900	SW. TACT SKHVAA
SW940	VG392900	SW. TACT SKHVAA
* U901	VR023400	L. DETCT SPS-424-1
* V901	VS550600	FL. DSPLY 13-BT-137GK
* VR901	VP741800	VR B20KΩ
* VR902	VP741900	VR G25KΩ
* VR903	VP742000	VR MN50KΩ
XL901	VE906000	RSNR. CE 4MHz
	VJ828000	PIN IMSA-6024-03E
	VR380100	SPACER FL-T6
	VR011400	SHEET. FL

* New Parts

DSP-A590

EXPLODED VIEW

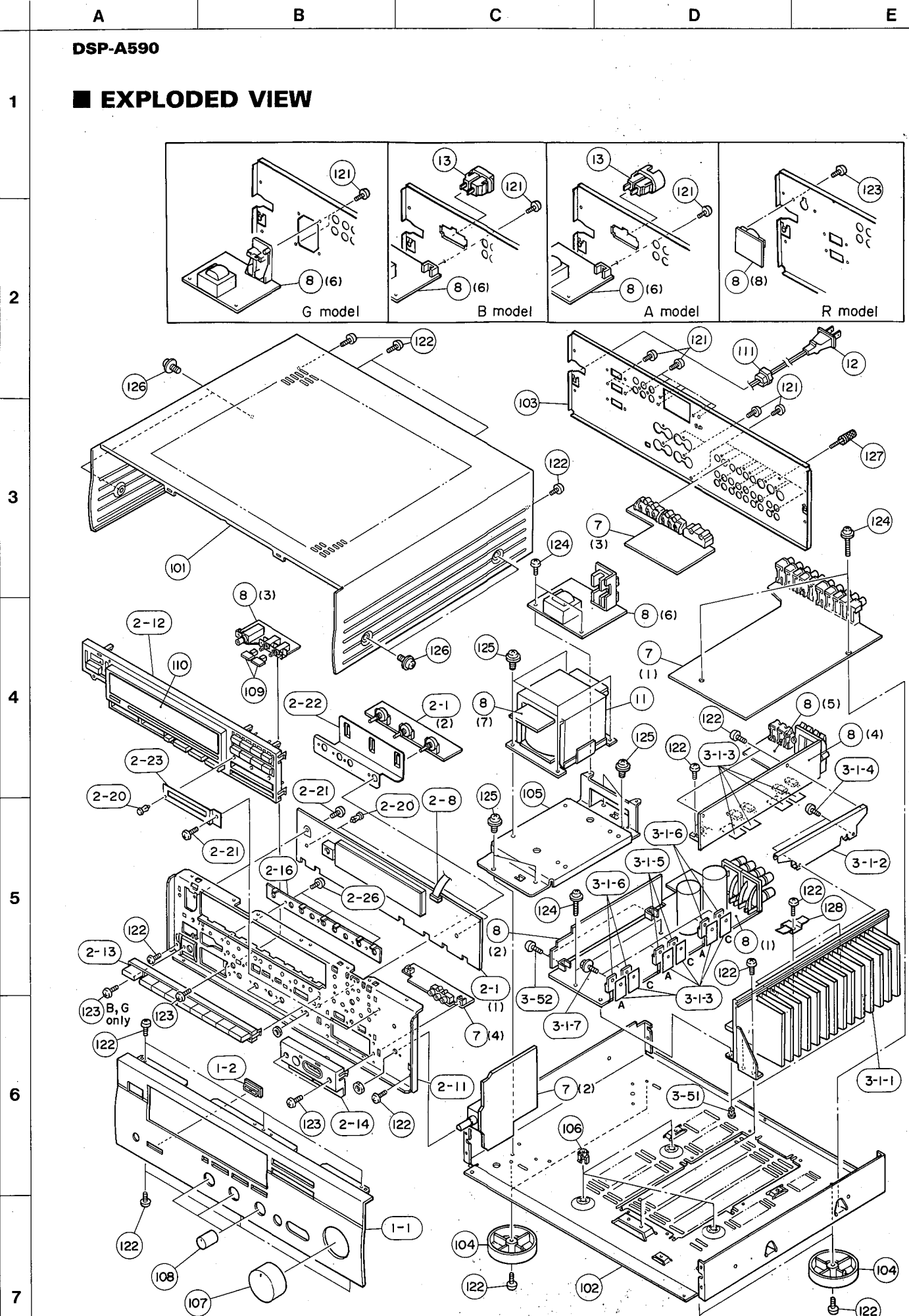

MECHANICAL PARTS

Ref. No.	PART NO.	Description	Remarks	Markets
* 1-1	VT004200	FRONT PANEL		TI
* 1-1	VT004300	FRONT PANEL		BL
* 1-2	VQ793400	BUTTON GUIDE		BL
* 1-2	VQ793500	BUTTON GUIDE		TI
* 2-1	VS710900	P.C.B. ASS'Y	OPERATION	(RA)
* 2-1	VS711000	P.C.B. ASS'Y	OPERATION	(BG)
* 2-8	VS756900	CONNECTOR, FLAT CABLE	15P 250mm	
* 2-11	VS003200	SUB CHASSIS		
* 2-12	VS003400	BUTTON, CASE		BL
* 2-12	VS324500	BUTTON, CASE		TI
* 2-13	VS003500	BUTTON, T		BL
* 2-13	VS414400	BUTTON, T		TI
* 2-14	VS195900	ESCUTCHEON		BL
* 2-14	VS196000	ESCUTCHEON		TI
* 2-16	VT305900	SUPPORT, T		
* 2-20	VQ368600	PUSH RIVET	P3555-B	
* 2-21	Ei330086	BIND HEAD B-TITE SCREW	3x8 FCRM3-BL	
* 2-22	VS865700	SHIELD PLATE		
* 2-23	VS906800	HOLDER		
* 2-26	Ei330066	BIND HEAD B-TITE SCREW	3x6 FCRM3-BL	
* 3-1-1	VS002400	HEAT SINK ASS'Y		
* 3-1-2	VQ796100	SUPPORT, PCB		
* 3-1-3	VK195900	SHEET	19x24	
* 3-1-4	Ei330086	BIND HEAD B-TITE SCREW	3x8 FCRM3-BL	
* 3-1-5	iX633340	TRANSISTOR	2SA1695 O,P,Y	Q531A
* 3-1-5	iX633350	TRANSISTOR	2SC4468 O,P,Y	Q531C
* 3-1-6	iX606460	TRANSISTOR	2SA1492 O,P,Y	Q523A, Q527A
* 3-1-6	iX606470	TRANSISTOR	2SC3856 O,P,Y	Q523C, Q527C
* 3-1-7	VK173200	SCREW, TRANSISTOR	3x15 SP FCM3	
* 3-51	VQ368600	PUSH RIVET	P3555-B	
* 3-52	ED330066	BIND HEAD SCREW	3x6 FCRM3-BL	
* 7	VS711300	P.C.B. ASS'Y	DSP	(RA)
* 7	VS711400	P.C.B. ASS'Y	DSP	(BG)
* 8	VS709600	P.C.B. ASS'Y	MAIN	(R)
* 8	VS709700	P.C.B. ASS'Y	MAIN	(A)
* 8	VS710000	P.C.B. ASS'Y	MAIN	(G)
* 8	VT208900	P.C.B. ASS'Y	MAIN	(B)
△* 11	XP965B00	POWER TRANSFORMER		(R)
△* 11	XP966B00	POWER TRANSFORMER		(AB)
△* 11	XP967B00	POWER TRANSFORMER		(G)
△* 12	VQ508500	POWER CORD ASS'Y		(R)
△* 12	VQ508600	POWER CORD ASS'Y		(A)
△* 12	VS168400	POWER CORD ASS'Y		(G)
△* 12	VS680700	POWER CORD ASS'Y		(B)
△* 13	VJ775000	AC OUTLET	2P	(B)
△* 13	VP418700	AC OUTLET	2P	(A)
* 101	VS001200	TOP COVER		BL
* 101	VS001300	TOP COVER		TI
* 102	VS001400	CHASSIS		
* 103	VS220900	REAR PANEL		(R)
* 103	VS221100	REAR PANEL		(G)
* 103	VS221700	REAR PANEL		(AB)
* 104	VQ780300	LEG	D60xH16	

* New Parts

Ref. No.	PART NO.	Description	Remarks	Markets
* 105	VS001900	FRAME, PCB		
* 106	VR264400	SPACER, H8		
107	VQ945600	KNOB	D42	VOLUME TI
107	VR021500	KNOB	D42	VOLUME BL
* 108	VS409600	KNOB	D18	BASS, TREBLE BL
* 108	VS409800	KNOB	D18	BASS, TREBLE TI
* 109	VQ779000	BUTTON	3x14	SPEAKERS BL
* 109	VQ779100	BUTTON	3x14	SPEAKERS TI
* 110	VS540900	SHEET, F		(RA)
* 110	VS541000	SHEET, F		(BG)
111	VN158600	CORD STOPPER	No. 2104	
121	EN301010	BIND HEAD BONDING TAP. SCREW	3x8 FCRM3-BL	
122	E1330086	BIND HEAD B-TITE SCREW	3x8 FCRM3-BL	
123	ED330066	BIND HEAD SCREW	3x6 FCRM3-BL	
124	EL300480	BW HEAD B-TITE SCREW	3x15-8 FCRM3-BL	
125	EL300470	BW HEAD S-TITE SCREW	4x8-10 FCRM3-BL	
126	EL300470	BW HEAD S-TITE SCREW	4x8-10 FCRM3-BL	BL
126	EX601150	BW HEAD S-TITE SCREW	4x8-10 FNM3-BL	TI
127	AA627310	GROUND TERMINAL		
* 128	VS349300	SUPPORT	TR	
		ACCESSORIES		
* 200	VS714000	REMOTE CONTROL TRANSMITTER		(7A, 7C)
200-1	CX675150	LID	54x32.9BLALPS	
		BATTERY, MANGANESE	SUM-3, AA, R06	

* New Parts

DSP-A590

A

B

C

D

E

DSP-A590

REMOTE CONTROL TRANSMITTER

■ SCHEMATIC DIAGRAM

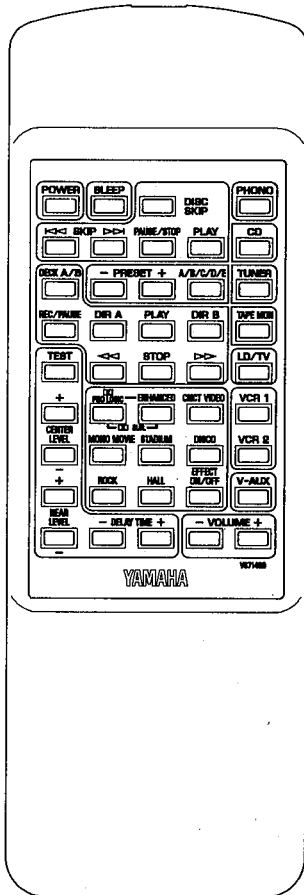
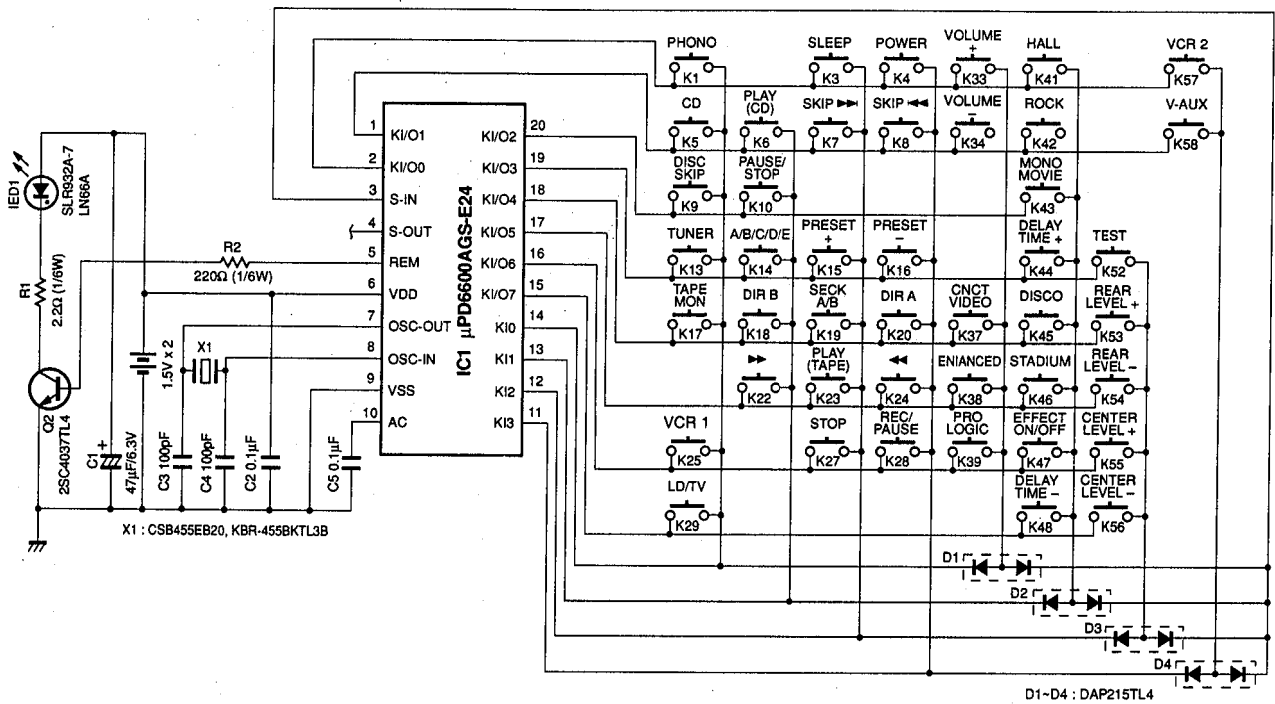

KEY No.	FUNCTION	CUSTOM CODE (HEX)	SUB CUSTOM CODE (HEX)	DATA CODE (HEX)	C0	C7	C0	C7	D0	D7	D0	D7
1	PHONO	7A	85	14	0101 1110	1010 0001	0010 1000	1101 0111				
3	SLEEP	7A	85	57	0101 1110	1010 0001	1110 1010	0001 0101				
4	POWER	7A	85	1F	0101 1110	1010 0001	1111 1000	0000 0111				
5	CD	7A	85	15	0101 1110	1010 0001	1010 1000	0101 0111				
6	PLAY (CD)	7A	85	08	0101 1110	1010 0001	0001 0000	1110 1111				
7	SKIP →	7A	85	0A	0101 1110	1010 0001	0101 0000	1010 1111				
8	SKIP ←	7A	85	0B	0101 1110	1010 0001	1101 0000	0010 1111				
9	DISC SKIP	7A	85	4F	0101 1110	1010 0001	1111 0110	0000 1101				
10	PAUSE/STOP (CD)	7A	85	09	0101 1110	1010 0001	1001 0000	0110 1111				
13	TUNER	7A	85	16	0101 1110	1010 0001	0110 1000	1001 0111				
14	A/B/C/D/E	7A	85	12	0101 1110	1010 0001	0100 1000	1011 0111				
15	PRESET +	7A	85	10	0101 1110	1010 0001	0000 1000	1111 0111				
16	PRESET -	7A	85	11	0101 1110	1010 0001	1000 1000	0111 0111				
17	TAPE MON	7A	85	18	0101 1110	1010 0001	0001 1000	1110 0111				
18	DIR B	7A	85	40	0101 1110	1010 0001	0000 0010	1111 1101				
19	DECK A/B	7A	85	06	0101 1110	1010 0001	0110 0000	1001 1111				
20	DIR A	7A	85	07	0101 1110	1010 0001	1110 0000	0001 1111				
22	→	7A	85	02	0101 1110	1010 0001	0100 0000	1011 1111				
23	PLAY (TAPE)	7A	85	00	0101 1110	1010 0001	0000 0000	1111 1111				
24	←	7A	85	01	0101 1110	1010 0001	1000 0000	0111 1111				
25	VCR 1	7A	85	0F	0101 1110	1010 0001	1111 0000	0000 1111				
27	STOP (TAPE)	7A	85	03	0101 1110	1010 0001	1100 0000	0011 1111				
28	REC/PAUSE	7A	85	04	0101 1110	1010 0001	0010 0000	1101 1111				
29	LD/TV	7A	85	17	0101 1110	1010 0001	1110 1000	0001 0111				
33	VOLUME +	7A	85	1A	0101 1110	1010 0001	0101 1000	1010 0111				
34	VOLUME -	7A	85	1B	0101 1110	1010 0001	1101 1000	0010 0111				
37	CONCERT VIDEO	7A	85	8A	0101 1110	1010 0001	0101 0001	1010 1110				
38	ENHANCED	7A	85	89	0101 1110	1010 0001	1001 0001	0110 1110				
39	PRO LOGIC	7A	85	88	0101 1110	1010 0001	0001 0001	1110 1110				
41	CONCERT HALL	7A	85	8D	0101 1110	1010 0001	1011 0001	0100 1110				
42	ROCK CONCERT	7A	85	8C	0101 1110	1010 0001	0011 0001	1100 1110				
43	MONO MOVIE	7A	85	8B	0101 1110	1010 0001	1101 0001	0010 1110				
44	DELAY TIME +	7A	85	52	0101 1110	1010 0001	0100 1010	1011 0101				
45	DISCO	7A	85	8F	0101 1110	1010 0001	1111 0001	0000 1110				
46	STADIUM	7A	85	8E	0101 1110	1010 0001	0111 0001	1000 1110				
47	EFFECT ON/OFF	7A	85	56	0101 1110	1010 0001	0110 1010	1001 0101				
48	DELAY TIME -	7A	85	53	0101 1110	1010 0001	1100 1010	0011 0101				
52	TEST	7A	85	85	0101 1110	1010 0001	1010 0001	0101 1110				
53	REAR LEVEL +	7A	85	5E	0101 1110	1010 0001	0111 1010	1000 0101				
54	REAR LEVEL -	7A	85	5F	0101 1110	1010 0001	1111 1010	0000 0101				
55	CENTER LEVEL +	7A	85	82	0101 1110	1010 0001	0100 0001	1011 1110				
56	CENTER LEVEL -	7A	85	83	0101 1110	1010 0001	1100 0001	0011 1110				
57	VCR 2	7A	85	13	0101 1110	1010 0001	1100 1000	0011 0111				
58	V-AUX	7A	85	55	0101 1110	1010 0001	1010 1010	0101 0101				

1

2

3

4

5

6

7

Parts List for Carbon Resistors

Value	1/4W Type Part No.	1/6W Type Part No.	Value	1/4W Type Part No.	1/6W Type Part No.
1.0 Ω	HJ35 3100	HF85 3100	10 kΩ	HF45 7100	HF45 7100
1.8 Ω	HJ35 3180	*	11 kΩ	HF45 7110	HF45 7110
2.2 Ω	HJ35 3220	HF85 3220	12 kΩ	HJ35 7120	HF85 7120
3.3 Ω	HJ35 3330	HF85 3330	13 kΩ	HF45 7130	HF45 7130
4.7 Ω	HJ35 3470	HF85 3470	15 kΩ	HF45 7150	HF45 7150
5.6 Ω	HJ35 3560	HF85 3560	18 kΩ	HF45 7180	HF45 7180
10 Ω	HF45 4100	HF45 4100	22 kΩ	HF45 7220	HF45 7220
15 Ω	HJ35 4150	HF85 4150	24 kΩ	HF45 7240	HF45 7240
22 Ω	HF45 4220	HF45 4220	27 kΩ	HJ35 7270	HF85 7270
27 Ω	HJ35 4270	HF85 4270	30 kΩ	HF45 7300	HF45 7300
33 Ω	HF45 4330	HF45 4330	33 kΩ	HF45 7330	HF45 7330
39 Ω	HJ35 4470	HF85 4390	36 kΩ	HF45 7360	HF45 7360
47 Ω	HF45 4470	HF45 4470	39 kΩ	HF45 7390	HF45 7390
56 Ω	HF45 4560	HF45 4560	47 kΩ	HF45 7470	HF45 7470
68 Ω	HF45 4680	HF45 4680	51 kΩ	HF45 7510	HF45 7510
75 Ω	HF45 4750	HF45 4750	56 kΩ	HF45 7560	HF45 7560
82 Ω	HF45 4820	HF45 4820	62 kΩ	HF45 7620	HF45 7620
91 Ω	HF45 4910	HF45 4910	68 kΩ	HF45 7680	HF45 7680
100 Ω	HF45 5100	HF45 5100	82 kΩ	HF45 7820	HF45 7820
110 Ω	HJ35 5110	HF85 5110	91 kΩ	HF45 7910	HF45 7910
120 Ω	HF45 5120	HF45 5120	100 kΩ	HF45 8100	HF45 8100
150 Ω	HF45 5150	HF45 5150	110 kΩ	HF45 8110	HF45 8110
160 Ω	HJ35 5160	*	120 kΩ	HF45 8120	HF45 8120
180 Ω	HF45 5180	HF45 5180	150 kΩ	HF45 8150	HF45 8150
200 Ω	HF45 5200	HF45 5200	180 kΩ	HF45 8180	HF45 8180
220 Ω	HF45 5220	HF45 5220	220 kΩ	HJ35 8220	HF85 8220
270 Ω	HF45 5270	HF45 5270	270 kΩ	HF45 8270	HF45 8270
330 Ω	HF45 5330	HF45 5330	300 kΩ	HF45 8300	HF45 8300
390 Ω	HF45 5390	HF45 5390	330 kΩ	HF45 8330	HF45 8330
430 Ω	HF45 5430	HF45 5430	390 kΩ	HJ35 8390	HF85 8390
470 Ω	HF45 5470	HF45 5470	470 kΩ	HF45 8470	HF45 8470
510 Ω	HF45 5510	HF45 5510	560 kΩ	HJ35 8560	HF85 8560
560 Ω	HF45 5560	HF45 5560	680 kΩ	HJ35 8680	HF85 8680
680 Ω	HF45 5680	HF45 5680	820 kΩ	HJ35 8820	HF85 8820
820 Ω	HF45 5820	HF45 5820	1.0 MΩ	HF45 9100	HF45 9100
910 Ω	HF45 5910	HF45 5910	1.2 MΩ	HJ35 9120	*
1.0 kΩ	HF45 6100	HF45 6100	1.5 MΩ	HJ35 9150	HF85 9150
1.2 kΩ	HF45 6120	HF45 6120	1.8 MΩ	HJ35 9180	HF85 9180
1.5 kΩ	HF45 6150	HF45 6150	2.2 MΩ	HJ35 9220	HF85 9220
1.8 kΩ	HF45 6180	HF45 6180	3.3 MΩ	HJ35 9330	HF85 9330
2.0 kΩ	HJ35 6200	HF85 6200	3.9 MΩ	HJ35 9390	*
2.2 kΩ	HF45 6220	HF45 6220	4.7 MΩ	HJ35 9470	HF85 9470
2.4 kΩ	HJ35 6240	HF85 6240			
2.7 kΩ	HF45 6270	HF45 6270			
3.0 kΩ	HF45 6300	HF45 6300			
3.3 kΩ	HF45 6330	HF45 6330			
3.6 kΩ	HJ35 6360	HF85 6360			
3.9 kΩ	HF45 6390	HF45 6390			
4.7 kΩ	HF45 6470	HF45 6470			
5.1 kΩ	HF45 6510	HF45 6510			
5.6 kΩ	HF45 6560	HF45 6560			
6.8 kΩ	HF45 6680	HF45 6680			
8.2 kΩ	HF45 6820	HF45 6820			
9.1 kΩ	HF45 6910	HF45 6910			

1/4W Type

HJ35 ○○○○

10mm

1/4W Type

HF45 ○○○○

1/6W Type

HF85 ○○○○

5mm

DSP-A590

DSP-A590

DSP-A590

DSP-A590

YAMAHA
